

*Union Internationale des Sciences Biologiques*

ORGANISATION INTERNATIONALE DE LUTTE  
BIOLOGIQUE ET INTEGREE CONTRE LES ANIMAUX  
ET LES PLANTES NUISIBLES

SECTION REGIONALE OUEST PALEARCTIQUE



ISBN 92-9067-012-6

WORKING GROUP:  
"MODELS IN INTEGRATED  
CROP PROTECTION"

GROUPE DE TRAVAIL:  
"MODELES EN PROTECTION  
INTEGREE"

edited by: D.J. ROYLE  
R. RABBINGE  
C.R. FLUCKIGER

BULLETIN SROP  
WPRS BULLETIN

1988/XI/2

*International Union of Biological Sciences*

INTERNATIONAL ORGANIZATION FOR BIOLOGICAL  
AND INTEGRATED CONTROL OF NOXIOUS  
ANIMALS AND PLANTS

WEST PALAEARCTIC REGIONAL SECTION



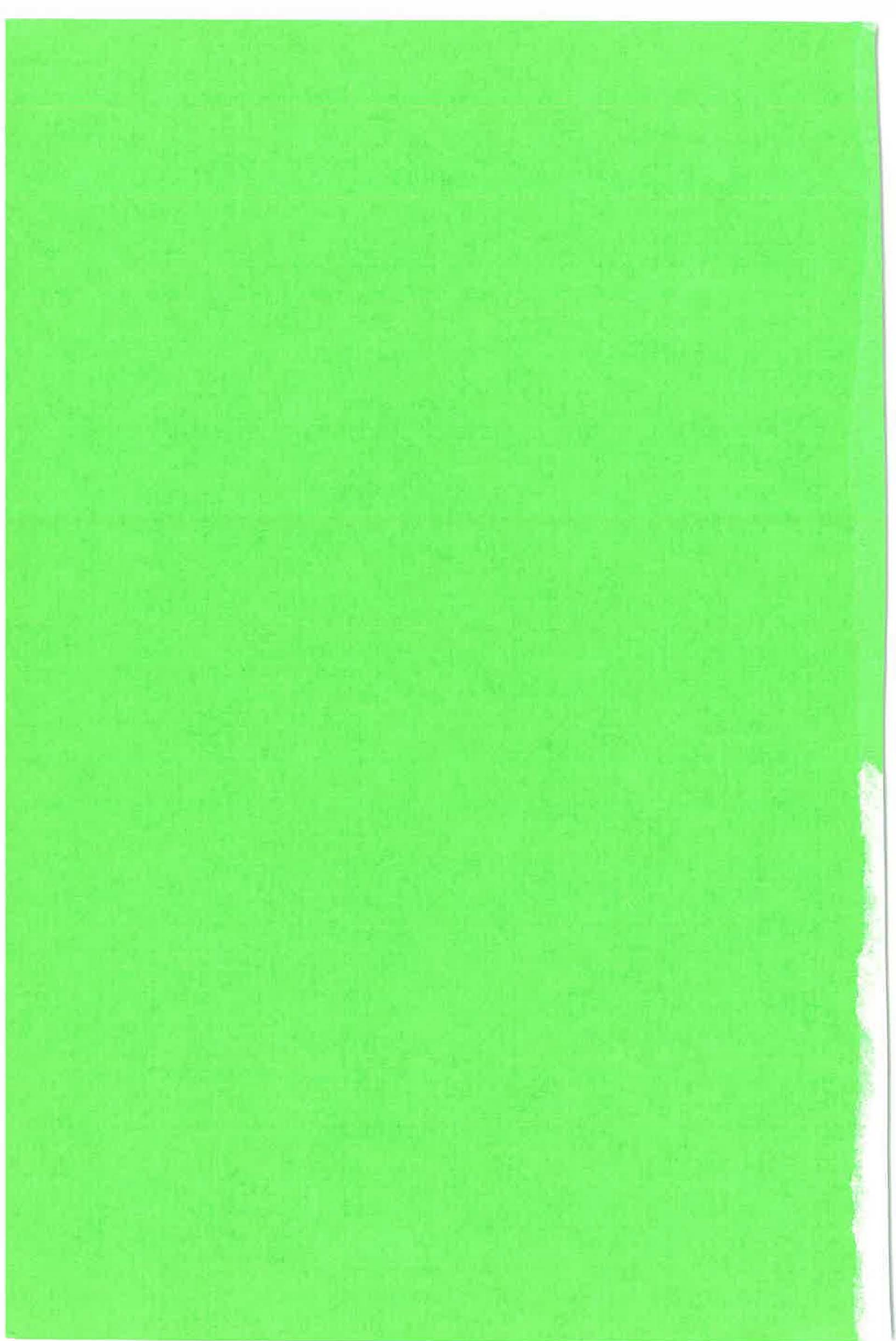

IOBC-WPRS/OILB-SROP  
Working Group - The Role of  
Models in Integrated Crop  
Protection

**PEST AND DISEASE MODELS IN FORECASTING,  
CROP LOSS APPRAISAL AND DECISION-SUPPORTED  
CROP PROTECTION SYSTEMS**

Edited by: D.J. ROYLE  
R. RABBINGE  
C.R. FLÜCKIGER

January 1988



P R E F A C E

This second bulletin of the IOBC/WPRS Working Group on the use of models in integrated crop protection marks 10 years of meetings of the Group. In the early years our discussions emphasised the methodology of model building and recognised a wide diversity in types of model - descriptive, predictive, conceptual, statistical, explanatory, comprehensive, summary models, to name a few. This phase of our work culminated in the first bulletin (1983/VI/2) which was essentially a guidebook on "The Development of Models for Practical Crop Protection".

In that bulletin, the objective of the Group was defined as "the co-ordination, initiation and development of models, systems analyses and databases for use in integrated pest control". This remains our aim, though the past 5 years have seen the emphasis appropriately shifting towards model implementation in agricultural and horticultural practice. Thus, the use of models in disease and pest forecasting, in crop loss appraisal and in the development of decision-based schemes of control has captured our attention. These are the themes for the collection of papers in this second bulletin.

There is little doubt that we, and others besides, have been too optimistic about the direct use of models to improve crop protection practices. Ten years ago the practical models were the simple ones, statistical rules or simple guidelines. Nowadays it is clear that good epidemiological, agronomical and population dynamic insights of, for example, the effects of disease and pest constraints on crop growth, are needed for the development of effective supervised or integrated crop protection systems. Therefore, nowadays, we distinguish much more explicitly between the various types of models: conceptual models, comprehensive explanatory models and summary or managerial models.

We have learned much and greatly improved the quality of our management tools through modelling these interactions of pest/disease and crop systems. Indeed, models function best to integrate this information, initially to aid understanding but then to distil information into forms which can be used simply and directly in crop protection practice.

D.J. Royle  
R. Rabbinge

January 1988

C O N T E N T S

PREFACE

I PEST AND DISEASE FORECASTING

C.R. Flückiger	Forecasting: An introduction ... ..	1
B. Hau	On the uncertainties of plant disease forecasts. ... ..	5
A. Mangstl & S. Rössler	Prognosis models in practice: requirements and examples ... ..	8
C.R. Flückiger, D. Randazzo & M. Koukolik	The use of models for cotton crop protection ... ..	12
J. Holt	A simulation analysis of brown planthopper dynamics in rice ... ..	19
V. Caffarelli & G. Vita	Heat accumulation for timing grapevine moth control measures ... ..	24
D. Morgan, N. Carter & F.C. Jepson	Modelling principles in relation to the epidemiology of barley yellow dwarf virus ... ..	27
J. Baumgärtner, J.-J. Favre & A. Schmid	Use of a time- varying distributed delay model for simulating the flight phenology of the summerfruit tortrix ( <i>Adoxophyes orana</i> ) in Valais, Switzerland... ..	33
A. Obst	Forecasting diseases of agricultural crops in Western Germany ... ..	38

II CROP LOSS AND DISEASE MONITORING

R. Rabbinge	Crop loss assessment and economic injury levels ... ..	42
R. Rabbinge & W.A.H. Rossing	Dynamic explanatory models as a tool in the development of flexible economic injury levels ... ..	48
M.W. Shaw & D.J. Royle	Conceptual basis for estimation of disease-induced crop loss in field experiments ... ..	62
R.A. Daamen	Disease/pest observation methods... ..	64

III IMPLEMENTATION OF PEST AND DISEASE MANAGEMENT SYSTEMS

R. Rabbinge	Implementation of integrated crop protection systems	69
B. Cure	Disease intelligence and decision-based systems in France	74
R.J. Cook	Cereal disease control in England and Wales: advice of the Agricultural Development and Advisory Service	80
J.C. Zadoks	EPIPARE: research, development and application of an integrated pest and disease management system for wheat	82
H.R. Forrer	Experience and current status of EPIPARE in Switzerland	91
A. Djurle	Experience and results from the use of EPIPARE in Sweden	94





## FORECASTING : AN INTRODUCTION

C.R. Flückiger

Agricultural Division, Research and Development Department,  
Ciba-Geigy SA, Basel, Switzerland.

We are now facing an information revolution. This statement can be found in many articles which deal with the future. Naisbitt (1982) has forecasted that technical information will increase 40% every year due to more powerful information systems and an increasing population of scientists. The Kellogg Foundation has predicted that by 1990 some 90% of commercial farms and 75% of county extension offices in the USA will be equipped with computers or intelligent terminals. The Control Data Corporation has stated in its publication "Doane's Agricultural Computing Directory 1985" that nearly all market studies conclude that agriculture has the highest market potential for computer application.

In the highly competitive environment of future agriculture, those who survive will be those who are able to acquire the most accurate and best organised information and use it most efficiently (Holt, 1985). Welch (1984) writes that there can be no doubt that computerization in agriculture will have as much impact as did farm mechanization several decades ago.

In plant protection the application of computer technology and systems research has led to the construction of different models used for guidance research, in forecasting, and in supervised and integrated control. Though these areas are interrelated, we will deal here mainly with forecasting.

Within crop protection, forecasting is a process of predicting future weed, pest or pathogen population sizes and the resulting losses in yield. Forecast models are becoming especially useful at the farm level where profit has to be optimized. To achieve this, it is necessary to forecast crop yields at the end of the season and the expected change in profit due to different management practices, including pesticide application. For this purpose strategic and tactical models may be used (Conway, 1984). Tactical methods give detailed advice in the short term or over a localised area, whereas strategic approaches emphasize long-term guidelines on how crops, weeds, pests or diseases develop and eventually could be tackled. Some of these models have been successfully applied in computer-based pest management systems (Ives et al., 1984; Welch, 1984; Zadoks, 1981).

Two kinds of forecasting models can be envisaged both of which can be very useful: (1) Process models are considered to be logical system models because they try to capture the complexities of the particular ecosystem. They use equations to relate specific system functions (state variables) to driving variables, usually from the environment. These are also called simulation models and can give rise to summary models and decision rules for forecasting, after sensitivity analysis and simplification have been performed.

2) Single-equation mathematical models, which operate at a much higher level and are of low resolution in depicting biological processes (Teng & Rouse, 1984; Flückiger *et al.*, 1986). These models are also called statistical models because they are often of the regression type.

Zadoks (1979) has suggested that simulation models, even though biologically more realistic than single-equation models, are less precise for disease forecasting. He claims that multiple regression models have incorporated a great amount of local experience within a few parameters, whereas simulation models emphasize general experience rather than level of local information.

Lemmon (1986) used a detailed process simulation model (GOSSYM) in his expert system (COMAX) for cotton crop management. This system operates the simulation model in the same way as a human expert, to determine agricultural practices. The advantage of this approach is to involve a large number of variables in order to describe the cotton crop in detail. The disadvantage of using a detailed simulation model to evaluate the impact of different management strategies is that, due to the large scale of the computations, only relatively few alternative management strategies can be examined. However, the experience with COMAX showed that enough alternatives could be calculated on a dedicated computer to make decisions that satisfied the farmer. Nevertheless, if a large number of management alternatives is required, simulation models need to be simplified in such a way that different minimisation or maximisation techniques can be applied to determine which management strategy optimizes a cost function.

The usefulness of mathematical modelling for practical management and forecasting cannot be based on or correlated with some general modelling scheme. The objective of each modelling activity has to be clearly defined. Far too often practitioners in pest and disease control criticize models for not performing in ways in which they expect them to perform. For example. They may not provide specific advice on day-to-day control, whereas their purpose may only be to establish general guidelines (Conway, 1984).

The section in this Bulletin on forecasting offers neither a review nor does it attempt to treat all aspects of the subject. The interested reader may refer to review articles on modelling and the systems approach (Baumgärtner & Delucchi, 1981; Conway, 1984; Getz & Gutierrez, 1982; Kranz & Hau, 1980; McKinion & Baker, 1982; Teng, 1985; Welch, 1984; Zadoks, 1984). The various papers presented in the following section describe some of the work which is currently being carried out by the members of the Working Group. They cover important steps (Rabbinge & Rijdsijk, 1983) in model construction, viz. define objectives, define limits of the system, conceptualize the elements of the system (state variables, rate variables, auxiliary variables, forcing variables), quantify relations, verification, validation, sensitivity analysis and simplification.

## References

- Baumgärtner, J. & Delucchi, V. (1981). Die Verwendung system-analytischer Methoden im Pflanzenschutz. Schweizerische landwirtschaftliche Forschung, pp. 136-144.
- Conway, G.R. (1984). Pest and pathogen control : Strategic, Tactical and Policy Models. International Institute for Applied Systems Analysis. John Wiley & Sons, 488 pp.
- Flückiger, C.R., Randazzo, D., & Koukolik, M. (1986). The use of models for cotton crop, protection. IOBC Bulletin, (this volume).
- Getz, W.M. & Gutierrez, A.P. (1982). A perspective on systems analysis in crop production and insect pest management. Annual Review of Entomology 27, 447-446.
- Holt, D.A. (1985). Computers in production agriculture. Science 228, 422-427.
- Ives, P.M., Wilson, L.T., Cull, P.O., Palmer, W.A., Haywood, C., Thomson, N.J., Hearn, A.B. & Wilson, A.G.L. (1984). Field use of SIRATAC: An Australian computer-based pest management system for cotton. Protection Ecology 6, 1-21.
- Kranz, J. & Hau, B. (1980). Systems analysis in epidemiology. Annual Review of Phytopathology 18, 67-83.
- Lemmon, H. (1986). COMAX: An expert system for cotton crop management. Science 233, 29-33.
- McKinion, J.M. & Baker, D.N. (1982). Modelling, experimentation, verification and validation: Closing the feedback loop. Transaction of the American Society of Agricultural Engineers 25, 647-653.
- Naisbitt, J. (1982). Megatrends. Warner Books Inc., New York, 333 pp.
- Rabbinge, R. & Rijsdijk, F.H. (1983). EPIPRE: A disease and pest management system for winter wheat taking account of micrometeorological factors. EPP0 Bulletin 13, 297-305.
- Teng, P.S. (1985). A comparison of simulation approaches to epidemic modelling. Annual Review of Phytopathology 23, 351-379.
- Teng, P.S. & Rouse, D.I. (1984). Understanding computers: Applications in plant pathology. Plant Disease 68, 539-543.
- Welch, S.M. (1984). Developments in computer-based IPM extension delivery systems. Annual Review of Entomology 29, 359-381.
- Zadoks, J.C. (1984). A quarter century of disease warning, 1958-1983. Plant Disease 68, 352-355.

Zadoks, J.C. (1981). EPIPPE: A disease and pest management system for winter wheat developed in the Netherlands. EPPO Bulletin 11, 365-369.

Zadoks, J.C. (1979). Simulation of epidemics: Problems and applications. EPPO Bulletin 9, 227-234.

ON THE UNCERTAINTIES OF PLANT DISEASE FORECASTS

B. Hau

Tropeninstitut, Justus-Liebig-Universität, D-6300 Giessen, Federal Republic of Germany.

Introduction

Forecasts in plant disease control are applied to predict disease occurrence, disease-free periods, disease progress and spray timing (Kranz, 1983). In this short paper we will confine ourselves to forecasts of disease progress and to those in which the essential components are the current disease situation, the anticipated weather for the period of prediction and a forecasting rule. The latter can be a simple regression equation or a complex simulation model. The effects of the host on disease progress, for example through adult plant resistance, is neglected in this example. By the nature of the above components of a forecast, uncertainties or errors in the forecasts are introduced. We will investigate how the error can be reduced by means of a hypothetical example.

Forecasts without uncertainties

If it is assumed that there are no uncertainties, a disease forecast will predict a specific disease intensity given the actual disease status and a precise weather forecast. Nagarajan and Joshi (1978), for example, developed a model to calculate weekly forecasts of wheat stem rust severity using temperature and relative humidity. For simplicity here we investigate the following hypothetical forecasting rule:

$$y(t+1) = y(t) + y(t) T 0.05,$$

in which  $y(t)$  is the current disease severity and  $y(t+1)$  the predicted severity after one time period with temperature  $T$ . The equation assumes that the increase of the disease is proportional to the actual disease severity and the presumed temperature. If, for instance, the actual disease severity is 5% and the anticipated temperature is 20°C, then the model will predict 10% severity after the next time period.

Forecasts with uncertainties

As mentioned above, the three components of a disease forecast are each subject to errors. Problems are caused by differences in macro- and microclimatic weather. Also there is insufficient resolution for local situations of weather data from standard stations (Schrvdter, 1983) which is not taken into consideration in many forecasts. Weather forecasts do not predict future weather accurately but deviate from the true situation according to a probability distribution. To deal with this one approach would be to apply the forecast rule to as many weather situations as possible, which will result in a frequency distribution of the disease predictions. This can lead to a conditional prognosis, as has been shown with a simulation model for barley powdery mildew (Hau et al., 1981). Such a prognosis states that a critical disease level can be reached only if certain weather conditions occur. In the mildew model it is now

assumed that the predicted temperature deviates from the true value according to a normal distribution, with a mean value corresponding to the real temperature (20°C) and a standard deviation of 1°C.

Let us go one step further. Not only are weather forecasts uncertain but the measure of the current state of a disease, used in the models, is also not faultless. Even if it were possible to measure or estimate precisely disease in a sample, different samples of the same size will show deviations. For example, suppose that the true disease severity and the mean value of possible samples is 5% and the standard deviation is 0.5%. Given a normal distribution, this implies that 95% of the sample means would lie between 4 and 6% disease severity.

Apart from these variations, the forecasting rule itself contains random errors, so that the predicted values vary even supposing disease assessments and weather forecasts are free from error. In regression models this is self-evident; each estimated regression coefficient is associated with a certain standard deviation. A similar variation is included in simulation models when stochastic elements are incorporated. In our example above, we assume that the coefficient is normally distributed with a mean of 0.05 and a standard deviation of 0.01.

Using the variation experienced in these components, forecasts were calculated by means of a Monte-Carlo simulation, with random numbers drawn from the computer. The frequency distribution of predicted disease severities is displayed in Fig. 1. The mean of the predicted values is 9.965% and the standard deviation 1.051%. The extreme values are 7.038% and 13.626%.

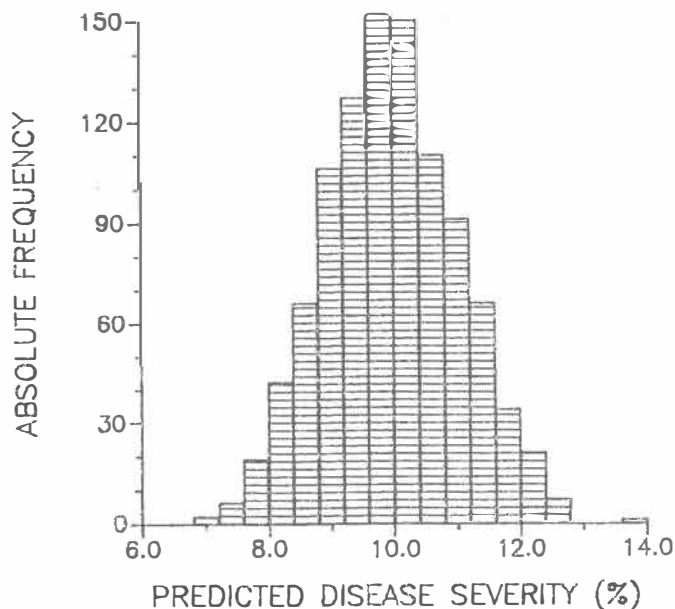

Fig. 1 Frequency distribution of predicted disease severities

It is often claimed that disease forecasts can be improved with better weather forecasts. Therefore, using the equation for the hypothetical forecasting rule, the outcome was tested when the temperature forecast is more accurate, so that the standard deviation around the true temperature is decreased to 0.5°C. Again, based on 1000 computations, the calculated disease severities are then characterized by a mean value of 9.966% and a standard deviation of 1.0283%. Obviously, in this example, a better temperature forecast decreases the variation of the predictions very slightly.

On the other hand, a disease forecast also depends on an assessment of the current state of disease. Therefore, greater accuracy in disease assessment, achieved by better methods or larger sample sizes, can improve disease forecasts. When, for instance, the standard deviation of the sample means in the above example can be lowered to 0.25, the mean disease severity of the 1000 forecasts would be 9.981% with a deviation of 0.568%, which is substantially better than with the improvement of the weather forecast. Finally, if we suppose that the standard deviation of the coefficient in the equation is only 0.005, then the variation of the predicted values changes only marginally, in comparison with the original predictions.

#### Conclusion

This note is intended to emphasize not only that "our imperfect attempts to predict pathogen behaviour in the environment are often due to our limited ability to forecast the environment" (Seem & Russo, 1983), but also that they are due to errors in disease assessment. Possibly the effect of disease assessment errors may not be as dominant in practical forecasts as in our hypothetical example, but it should be pointed out that besides improved weather forecasts in the future, a greater accuracy in disease assessment to-day can make disease predictions more secure.

#### References

- Hau, B., Kranz, J. and Schrödter, H. (1981). Zum Konzept der Konditional-prognose. Mitteilungen Biologische Bundesanstalt Land Forstwirtschaft Berlin-Dahlem 203, 304.
- Kranz, J. (1983). Forecasting - scope and problems. Arabian Journal of Plant Protection 1, 54-57.
- Nagarajan, S. and Joshi, L.M. (1978). A linear model for a seven-day forecast of stem rust severity. Indian Phytopathology 31, 504-506.
- Schrödter, H. (1983). Meteorological problems in the practical use of disease-forecasting models. EPP0 Bulletin 13, 307-310.
- Seem, R.C. and Russo, J.M. (1983). Predicting the environment. In: Challenging problems in plant health. (Kommedahl, T. and Williams, P.H., eds.) pp. 226-238, American Phytopathological Society, St. Paul, Minnesota.

## PROGNOSIS MODELS IN PRACTICE: REQUIREMENTS AND EXAMPLES

A. Mangstl and S. Rössler

Technische Universität München,  
Lehrinheit Ackerbau und Versuchswesen  
D 8050 Freising-Weihenstephan, Federal Republic of Germany

### Models: time and purpose

Ideally, the purpose of a prognosis model is to enable a treatment to be applied to crops only when it is economically advantageous. The deciding factor for treatment should not be maximisation of yield but maximisation of profit, taking into account protection of the environment. The model should estimate the increase in profit resulting from a treatment at the time circumstances trigger the model.

The following factors must either be known or else determinable:

- (i) The relationship between a measure or estimate of disease and the resulting damage in terms of loss in yield, reduction in quality or increased harvesting costs
- (ii) The characteristic trend of an epidemic from a known initial amount of disease, environmental conditions and the conditions favouring infection
- (iii) The amount of infection which is economically critical. This depends on such factors as crop yield, the cost of pesticides, labour and equipment, the price of the end product, and the chances of success of the treatments.

When several infections occur simultaneously each cannot be analysed in isolation.

### Data required

The farmer has to collect the necessary data required by the model. Certain data, e.g. weather, are available from standard meteorological stations.

General warnings serve as indicators of the general need for treatment. They are not suitable decisions on particular treatments in individual crop fields.

Weather. In most cases weather is the main factor influencing infection. However, data are usually not available in the required detail. In this situation there are various options:

- (i) Special instruments can be used to indicate the start of infection weather at specific locations (e.g. wetness/temperature recorders for apple scab, Venturia inaequalis).
- (ii) Estimation of the severity of infection can be derived from weather data provided by official meteorological stations (as with cereal eyespot, Pseudocercospora herpotrichoides, and potato blight, Phytophthora infestans; see Obst, this Bulletin).
- (iii) Use of individual weather stations coupled to process computers (PC).



Due to technical difficulties, these options have so far been used in practice only in a few cases.

Disease observations. Field observations must be defined in a manner capable of being carried out by non-experts. They should occupy little time and not need complicated technical aids. Methods using small samples (40-100 plants) have proved sufficiently accurate (as in EPIPPE). Methods requiring precise measurements are not acceptable, neither are those requiring complicated evaluation.

A simple definition of the incidence of disease is practical, even though it may be imprecise. The Dutch supervised control system for winter wheat, EPIPPE, has shown that such estimations can be part of a successful scheme (see Zadocs, this Bulletin).

Field and crop data. Data on variety, previous crop, soil analysis, fertilisation, etc. are virtually always available but alone are not adequate for prognosis. Several experiments using such data for prognosis of eyespot have been conducted (Effland, 1975; Fehrmann & Schrödter, 1971, 1972; Siebrasse, 1982) although information on weather conditions is still necessary.

#### Model accessibility

Prognosis models need to be available to the farmer and be applicable to individual fields. General warnings over radio or telephone are usually not sufficiently specific. Communication between a centralised computer and the farmer by mail is possible but the problems of organisation are enormous. A solution is to use a direct link to the computer via Videotex, which is inexpensive. This offers the advantage of using central meteorological data. Programs for a PC are more complicated; they could be coupled to small on-line weather stations.

#### Examples of prognosis models

Models without an economic evaluation. Besides the official State Warning Service, which in many countries depends on disease surveys, there are several other examples in which the risk of diseases is estimated:

- (i) A warning service for apple scab depends on the duration of leaf wetness to indicate periods unfavourable to infection (negative prognosis).
- (ii) Hop downy mildew (*Pseudoperonospora humuli*) warnings are based on trapping flights of airborne spores to determine the start of potential infection (Kremheller, 1979).
- (iii) Prognosis of cereal eyespot is estimated from a points system where a treatment is recommended when the sum total exceeds a certain value (Effland, 1975).
- (iv) The German official meteorological warning service for eyespot uses an index value for meteorological conditions in different areas. This helps to make a decision as to the optimal time to spray (Fehrmann & Schrödter, 1971, 1972).
- (v) In Phyteb, a warning service for potato blight, the danger level for various areas is determined from weather conditions (Gutsche & Kluge, 1983).

(vi) An estimation of the danger level of Septoria nodorum in wheat is made from weather observations and soil factors. This has the advantage of linking to a Videotex service with central storage of weather data. An economic evaluation is being incorporated (Englert, 1983; Rössler, 1986).

#### Models with an economic evaluation.

(i) EPIPRE is an estimation of loss in winter wheat caused by pests and diseases. The amount of monitoring time to evaluate the degree of disease/pest incidence is kept as low as possible. Included are models for brown rust (Puccinia recondita), stripe rust (Puccinia striiformis), mildew (Erysiphe graminis) etc. The dynamic development of disease is estimated (Rabbinge & Rijdsdijk, 1983; Zadoks, this Bulletin).

(ii) Estimation of eyespot according to the method of Fehrmann & Schrödter, 1972). Here the loss of production is estimated from the weather conditions and agricultural factors.

(iii) Estimation of eyespot using the method of Siebrasse (1982) in which the influences of various factors are expressed in multiple regression equations.

(iv) In Herbis (Gerowitt et al., 1986), the necessity for weed control is evaluated using a multiple regression model with field observations. The estimated quantity is the loss of output.

#### Conclusions

The aims of integrated disease and pest control are generally well known. Intensive work is being done in the FDR to realise these ecological production goals. Progress, however, is slow because of several factors. The major problem lies in the cumbersome calculation methods and the many different types of disease assessments. Therefore, it is only possible to achieve integrated methods if prognosis models are available and usable in practice.

In future, the components of a given system need to be integrated into a single software package to provide a framework for computer-integrated pest and disease control. The central data storage in this concept is the field catalogue from which prognosis methods obtain data. In West Germany there already exists an integrated software package for Videotex (CIPP-Btex) (Reiner et al., 1985; Mangstl et al., 1986).

#### References

- Effland, K. (1975). Prognose der Halmbruchkrankheiten. Kurz und Bündig 7, 147.
- Englert, G. (1983). Die Spelzenbräume (Septoria nodorum) beim Weizen und der Versuch einer frühzeitigen Befallsprognose aufgrund der Witterung zum Zeitpunkt des Ährenschiebens. Dissertation, TU-München-Weihenstephan.
- Fehrmann, H. & Schrödter, H. (1971). Ökologische Untersuchungen zur Epidemiologie von Cercospora herpotrichoides. I. Jahreszeitliche Abhängigkeit von Weizeninfektionen im Freiland. Phytopathologische Zeitschrift 71, 66-82.

Fehrmann, H. & Schrödter, H. (1971). Ökologische Untersuchungen zur Epidemiologie von Cercospora herpotrichoides. IV. Erarbeitung eines praxisnahen Verfahrens zur Bekämpfung der Halmbrechkrankheit des Weizens mit systemischen Fungiziden. Phytopathologische Zeitschrift 74, 161-174.

Gerowitt, B., Heitefuss, R., Fischer, A. & Reiner, L. (1986). Versuche zur Erarbeitung von Kriterien für EDV-gestützte Entscheidungshilfen zur Unkrautbekämpfung nach Schadschwellen im Wintergetreide. Proceedings EWRS Symposium 1986, Economic Weed Control, pp. 351-360.

Gutsche, V. & Kluge, E. (1983). Phyteb - ein Vorhersageverfahren zur Krautfäulebekämpfung. Nachrichtenblatt für den Pflanzenschutz der DDR 37, 45-49.

Kremheller, H.T. (1979). Untersuchungen zur Epidemiologie und Prognose des falschen Mehltaus an Hopfen (Pseudoperonospora humuli). Dissertation, Technischen Universität München-Weihenstephan.

Mangstl, A., Bergermeier, J. & Rössler, S. (1986). Düngung und Pflanzenschutz mit Hilfe von Planungs- und Prognosemodellen. Bayerisches Landw. Jahrb. (In Press).

Reiner, L., Bergermeier, J.-H., Brenner, K., Rössler, S., Fischer, A. & Penger, A. (1985). Integrierte Pflanzenproduktion durch EDV Planungs- und Prognosemodelle. Bayerisches Landw. Jahrb. 1, 43-48.

Rössler, S. (1986). Integrierter Pflanzenschutz bei Winterweizen mit Hilfe von Prognosemodellen im System Bildschirmtext. Dissertation, TU-München-Weihenstephan.

Siebrasse, G. (1982). Zur Entwicklung eines mathematischen Modells für ein praxistgerechtes Halmbrechwarnsystem in Winterweizen. Dissertation, TU-München-Weihenstephan.

Rabbinge, R. & Rijsdijk, F.H. (1983). EPIPPE: a disease and pest management system for winter wheat, taking account of micrometeorological factors. EPPA Bulletin 13., 297-305.

THE USE OF MODELS FOR COTTON CROP PROTECTION

C.R. Flückiger  
Agricultural Division, Research and Development Department,  
Ciba-Geigy SA, Basel, Switzerland

D. Randazzo and M. Koukolik,  
Research Department, Modelling and Simulation Unit, Ciba-Geigy SA,  
Basel, Switzerland

Introduction

The use of models in pest management has increased rapidly since their initial utilization in the early sixties (Getz and Gutierrez, 1982; Heong, 1982; Teng, 1985). For the most important crops, attempts have been made to construct explanatory crop simulation models. Among the crops that have been modelled are alfalfa, apple, barley, cotton, corn, peanut, potato, rice, soybean, sorghum, sugarbeet, tomato and wheat. Attempts have also been made to develop simulation models for almost all the major pests. Examples of pest models which have been linked to existing crop models are numerous (Brown *et al.*, 1979; Gutierrez *et al.*, 1979; Gutierrez *et al.*, 1984; Mishoe *et al.*, 1984; Rabbinge *et al.*, 1981). Such models are used in research, teaching and extension (Welch, 1984). They are also being used in the recent development of expert systems (Lemmon, 1986; McKinion and Lemmon, 1985). Due to its economic significance, considerable effort has been directed towards the modelling of cotton; Ciba-Geigy began such an exercise about 3 years ago.

Many models have been developed both for the cotton plant (Table 1) and cotton insect pests (Table 2). Different characteristics have been suggested to classify models (Conway, 1984; Heong, 1982; Jackson & Arkin, 1982). In Table 1 three categories of cotton crop models are presented according to the following scheme:

(i) Complex Process Models are built from a physiological point of view. These attempt to identify and describe the main processes in the crop growth cycle. The input of these models, (the environmental conditions and the cultural practices which exist during the growing season), determine the yield predictions. The individual process components must each have a level of accuracy sufficiently high to ensure that the prediction from the combined system will provide useful predictions over a broad range of growth conditions. These models are usually difficult to calibrate, because many process components may have their own calibration parameters; thus complete calibration may require the simultaneous calibration of many parameters. Computer processing time can be high for such models, but this factor becomes less important as the present day computers become faster and more efficient (McKinion & Baker, 1982).

(ii) Simple Process Models have a more simple structure. Certain process aspects are described in great detail whereas others are either omitted or treated more simply. Thus, these models are usually more transparent and easier to understand and calibrate.

(iii) Single Equation or Limited Scope Process Models often consist of a single algorithm which describes only one aspect of the system. They are oriented towards a clearly defined use.

Authors of Detailed Process Models often criticize the view of builders of other kinds of models that model complexity and structure should be dictated by its intended purpose of application.

**Table 1 - Categorized Partial List of Cotton Model**

<b>Complex Process Models</b>	
COTTON	(Stapelton et al., 1973)
SIMCOT	(McKinion et al., 1975; Baker et al., 1972)
COTCROP	(Jones et al., 1980; Brown et al., 1985)
GOSSYM	(Baker et al., 1983)
KUTUN	(Mutsaers, 1982)
<b>Simple Process Models</b>	
COTSIM	(Wang et al., 1977)
COTTAM	(Jackson et al., 1984)
FRUITING MODEL	(Curry et al., 1980)
<b>Single Equation or Limited Scope Models</b>	
FRUITING FORMS	(Wallach, 1980)
SIRATAC	(Hearn et al., 1981; Ives et al., 1984)
BOLL PERIOD	(Wanjura + Newton, 1981)

**Table 2 - Models for cotton insects**

<b>Anthonomus grandis</b>		<b>Lygus</b>
WEEVIL-COTTON	(Curry et al., 1980)	Gutierrez and Wang (1979)
COTSIM BOLLWEEVIL	(Gutierrez et al., 1979)	
BWEEV	(Brown et al., 1979)	<b>Bemisia</b>
BWSIM	(Jones et al., 1975)	Von Arx et al. (1983)
<b>Heliothis</b>		<b>Beneficials</b>
MOTHZV	(Hartstack et al., 1976)	Goodenough et al. (1983)
SIRATAC	(Ives et al., 1984)	Brown et al. (1979)
HEL SIM	(Stinner et al., 1974)	
HEL SYS	(Brown et al., 1979)	

Flückiger (1986) distinguished between process models ((i) and (ii) above) and single equation models ((iii) above). The use of models for cotton crop protection presented in this paper emphasizes the Detail Process models.

**Objective**

The major goals of our modelling activity are to understand:

- (i) What effects infestation and damage at different infestation stages of growth have on yield.
- (ii) How economic is the use of the insecticide to reduce infestation and damage at different stages of growth.
- (iii) The biological activity of an insect protectant under field conditions.

Statistical methods alone, due to their static nature, often have failed in these goals. Therefore, it seems to be more appropriate to use a systems (modelling) approach.

Models enable us to estimate changes in yield and profit at the end of the season in response to management practices, such as insecticide application. We have conducted preliminary studies to find optimal control strategies against Heliothis zea and H. virescens. After completion of our work on validation, final results will be presented.

Crop-pest simulation models are tools to understand the crop system and to deduce optimal management practices. They are one of the tools which enable us to select and use control agents (chemicals and biologicals) more efficiently.

#### Models used

From the model mentioned in Tables 1 and 2, we selected several important ones in order to start our modelling investigation. On the cotton crop, we implemented COTCROP, GOSSYM, COTSIM and COTTAM and studied their algorithms. Among the Associated insects we chose one Boll Weevil model (Brown et al., 1979), two Heliothis models (Brown et al., 1979; Hartstack et al., 1976) and one algorithm to consider beneficials (Brown et al., 1976) and one algorithm to consider beneficials (Brown et al., 1979). Models for insecticide applications against Heliothis were developed in house.

In order to be able to investigate pest management strategies, it is necessary to link crop models with pest models. We therefore first used the model of Brown et al. (1979) in which a cotton crop model, a Boll Weevil model and a Heliothis model were interfaced. In a second approach we are concatenating the cotton crop model GOSSYM, which does not include any insects, with the Heliothis model HELSYS (Table 1 and 2).

#### Validation

The usefulness of these models is mainly restricted by the accuracy of the data employed in preparing and developing those algorithms which describe the plant and insect development. A model which is formulated using poor data can yield useless or even misleading predictions, yet a valid model will be extremely useful. This was done mainly by comparing the model predictions with the observations from the Ciba-Geigy experimental farms in the USA.

All the models that we are using have been previously validated more or less extensively by Universities and the United States Department of Agriculture. Usually these validations were done in collaboration with the author of the model. Nevertheless, with our new data, we believe that an independent validation is still necessary. We are therefore investing a lot of effort in this direction. The major activities in this validation phase were of three kinds:

- (i) Review of the existing computer code. This phase consisted of a critical view of the programs for the purpose of eliminating coding errors and any logical inconsistencies. Most of these models were developed by many different people, some of them without formal training in programming. The result is a diversity of styles and standards.

Sometimes mistakes occurred in the construction due to misinterpretation of another author's code. Any correction of the code, which changes one biological process, may require a new calibration of the model.

**Table 3 - Validation data measured throughout the season**

**A) The cotton plant**

- a) Plant phenology:  
The number of the following units per 75 cm row of cotton:  
1 Number of plants  
2 Number of nodes above seedling leaves on mainstem (the total number on all the plants in that 0.75 meter row of cotton)  
3 Number of pinhead squares (lt. 0.25 inch)  
4 Number of large squares (gr. 0.25 inch)  
5 Number of white bolls  
6 Number of green bolls (included red and dried bolls)  
7 Number of open bolls
- b) Dry matter weight of plant material for  
1 leaves  
2 stems  
3 squares  
4 bolls
- c) Leaf area index

**B) The insects**

**Heliothis**

- a) Catches of males per night separately for H. zea and H. virescens  
b) Eggs in terminals  
c) Larvae in terminals, squares and bolls  
d) Damage in terminals, squares and bolls

**Anthonomus grandis**

Damages of feeding and oviposition are counted.

**Lygus**

Nymphs and adults are counted in drop sheets.

**Other pests**

Any other pest which occurs is registered quantitatively.

**Predators**

On some years at some locations predator densities are registered after a method of Sechser (1984).

- (ii) Validation by comparing the calculated value of the model with our measured cotton data from the field (plant, insects, weather, agricultural practices etc.) The field variables from the cotton plants and insects are listed in Table 3. These data were collected in 1983 in Arkansas, in 1984 in California and in 1984-86 in Mississippi.

For every location simulations are being made with the models we implemented as mentioned before. The results of the computer simulations are compared with the observations from the field. No model has to the present been able to quantitatively represent all the observed data from all the authors. What we are at present seeking is rather qualitative agreement between model and data as we vary variables in a predetermined manner.

- (iii) Comparison of the simulated results from different models. Information from this comparison enables us to combine positive aspects of the different models.

Our validation work is being continuously discussed with the authors of the different models with an eye towards explaining the differences between the measured and calculated results. An example of such a comparison between observations in the field and calculations by the model (GOSSYM) is given in Fig. 1.

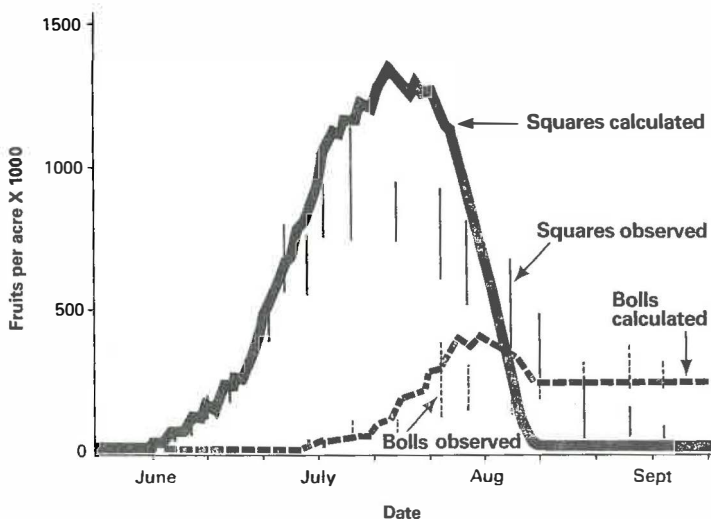

Figure 1: Simulated and observed development of squares and bolls at the Delta Farm 1984. Vertical lines indicate the 95% confidence interval of the observed value. This simulation was done with the Gossym Simulation Model.

#### Acknowledgements

The authors thank Don Hays and Ngoan Ngo from the Delta Farm and Janet Moore, from Ciba-Geigy, USA, for contributing to this project.

#### References

- Baker, D.N., Lambert, J.R. and McKinion, J.M. (1983). GOSSYM: A simulator of cotton crop growth and yield. South Carolina Agricultural Experiment Station Technical Bulletin 1089, 134 pp.
- Baker, D.N., Hesketh, J.D. and Duncan, W.G. (1972). Simulation of growth and yield in cotton. Crop Science  $\pm^2$ , 431-435.
- Brown, L.G., Jones, J.W., Hesketh, J.D., Hartsog, J.D., Whisler, F.D. and Harris, F.A. (1985) COTCROP: Computer simulation of cotton growth and yield. Mississippi Agricultural and Forestry Experiment Station Information Bulletin 69, 117 pp.
- Brown, L.G., McClendon, R.W. and Jones, J.W. (1979). Computer simulation of the interaction between cotton crop and insect pests. Transactions of the ASAE  $\pm^2$ , 771-774.



Conway, G.R. (1984). Pest and pathogen control. Strategic, tactical and policy models. International Institute for Applied Systems Analysis, John Wiley & Sons, 488 pp.

Curry, G.L., Sharpe, P.J.H. and DeMichele, D.W. (1980). Towards a management model of the cotton-boll weevil ecosystem. Journal of Environmental Management ±±, 187-223.

Flückiger, C. (1987). Forecasting: An introduction (this volume).

Getz, W.M. and Gutierrez, A.P. (1982). A perspective on systems analysis in crop production and insect pest management. Annual Review of Entomology 27, 447-466.

Goodenough, J.L., Hartstack, A.W. and Pieprzica, K.A. (1983). Dynamic model of a pest insect parasite. ASAE Summer Meeting, 1983, Paper No. 83-1005, 72 pp.

Gutierrez, A.P., Baumgaertner, J.U. and Summers, C.G. (1984). Using crop pest models for management applications. Agricultural Systems 15, 153-170.

Gutierrez, A.P. and Wang, Y. (1979). An optimization model for Lygus hesperus (Heteroptera: Miridae) damage in cotton: The Economic Threshold Revisited. Canadian Entomologist 111, 41-54.

Gutierrez, A.P., Wang, Y. and Daxl, R. (1979). The interaction of cotton and boll weevil (Coleoptera: Curculionidae) - A study of co-adaptation. Canadian Entomologist 111, 357-366.

Hartstack, A.W., Witz, J.A., Hollingsworth, J.P., Ridgway, R.L. and Lopez, J.D. (1976). MOHZV-2: A computer simulation of Heliothis zea and Heliothis virescens population dynamics. USDA, ARS-S-127 (User's Manual).

Hearn, A.B., Ives, P.M., Room, P.M., Thompson, N.J., Wilson, L.T. (1981). Computer-based cotton pest management in Australia. Field Crops Research 4, 321-332.

Heong, K.L. (1982).. The role of models in pest management programmes. Proceedings International Conference of Plant Protection in the Tropics, pp. 567-579.

Ives, P.M., Wilson, L.T., Cull, P.O., Palmer, W.A., Haywood, C., Thompson, N.J., Hearn, A.B. and Wilson, A.G.L. (1984). Field use of SIRATAC: An Australian computer-based pest management system for cotton. Protection Ecology 6, 1-21.

Jackson, B.C. and Arkin, G.F. (1982). Fruit growth in a cotton simulation model. Texas Agricultural Experiment Station (internal report).

Jackson, B.S., Arkin, G.F. and Hearn, A.B. (1984).; Cotton fruiting model: calibration and testing. American Society for Agricultural Engineers Paper No. 84-4542.

- Lemmon, J.H. (1986). COMAX: An expert system for cotton crop management. Science 233, 29-33.
- McKinion, J.M. and Lemmon, H.E. (1985). Expert systems for agriculture. Computers and Electronics in Agriculture 1, 31-40.
- McKinion, J.M. and Baker, D.N. (1982). Modelling, experimentation, verification and validation: Closing the feedback loop. Transactions of the American Society of Agricultural Engineers 25, 647-653.
- McKinion, J.M., Baker, D.N. Hesketh, J.D. and Jones, J.W. (1975). SIMCOT II: A simulation of cotton growth and yield. In: Computer Simulation of a Cotton Production System: User's Manual. USDA-ARS-S-52, April, 1975.
- Mishoe, J.W., Jones, J.W., Swaney, D.P. and Wilkerson, G.C. (1984). Using crop pest models for management applications. Agricultural Systems 15, 153-170.
- Mutsaers, H.J.W. (1982). KUTUN: A morphogenetic model for cotton (Gossypium hirsutum L.) Thesis, Agricultural University, Wageningen, 99 pages.
- Rabbinge, R., Drees, E.M., van der Graaf, M., Verberne, F.M.C. and Wesselo, A. (1981). Damage effects of cereal aphids in wheat. Netherlands Journal of Plant Pathology 87, 217-232.
- Sechser, B. (1984). Comparative toxicity of some insecticides to the beneficial complex of cotton in Egypt, Brazil and USA. Abstract Volume 17. International Congress of Entomology, Hamburg. p. 733.
- Stapelton, H.N., Buxton, D.R., Watson, F.L., Nolting, D.J. and Baker, D.N. (1973). COTTON: A computer simulation of cotton growth. Arizona Agricultural Experimental Station Technical Bulletin No. 123.
- Stinner, R.E., Rabb, R.L. and Bradley, J.R. (1974). Population dynamics of Heliothis zea (Boddie) and H. virescens (F.) in North Carolina: a simulation model. Environmental Entomology 3, 163-168.
- Teng, P.S. (1985). A comparison of simulation approaches to epidemic modeling. Annual Review of Phytopathology 23, 351-379.
- Von Arx, R., Baumgärtner, J. and Delucchi, V. (1983). A model to simulate the population dynamics of Bemisia tabaci Genn. (Stern., Aleyrodidae) on cotton in the Sudan Gezira. Zeitschrift angewandte Entomologie 96, 343-363.
- Wallach, D. (1980). An empirical mathematical model of a cotton crop subject to damage. Field Crops Research 3, 7-25.
- Wang, Y., Gutierrez, A.P., Oster, G. and Daxl, R. (1977). A population model for plant growth and development: Coupling cotton-herbivore interaction. Canadian Entomologist 109, 1359-1374.
- Wanjura, D.F. and Newton, O.H. (1981). Predicting cotton crop boll development. Agronomy Journal 73, 476-481.
- Welch, S.M. (1984). Developments in computer-based IPM extension delivery systems. Annual Review of Entomology 29, 359-381.

A SIMULATION ANALYSIS OF BROWN PLANTHOPPER DYNAMICS ON RICE

J. Holt

Silwood Centre for Pest Management, Imperial College at Silwood Park  
Ascot, Berkshire, UK, SL5 7PY

Introduction

The dynamics of brown planthopper (*Nilaparvata lugens*) populations in the tropics do not show a predictable pattern (Dyck *et al.*, 1979). Immigration occurs throughout the crop period (Cook & Perfect, 1985) and polyphagous predators are an important cause of brown planthopper (bph) mortality (Kenmore *et al.*, 1984). In this paper we describe how systems analysis techniques have been used to investigate the dynamics of bph populations in the tropics.

Objectives

(1) Determination of the key system components which influence the dynamics of bph on rice. A knowledge of these components and of the extent of their influence should enable monitoring methods to be devised which comprise the necessary information for the prediction of subsequent bph outbreaks at specific sites.

(2) Investigation of the impact on modelled bph populations of management activities, including those designed to control bph and other rice pests. This should generate questions and hypotheses concerning the improvement of rice pest management.

(3) The initial work focussed on bph dynamics in the Philippines, at several sites over a 5-year period (Perfect *et al.*, 1983). The implications for management of the differences between bph dynamics in different countries constitutes the third main objective.

Descriptive analysis

This work focussed on events within the paddy field from transplanting (or seeding) to harvest, and the model represented a specific plot of rice over this period. Before embarking on computer simulation modelling, a systematic descriptive analysis of the rice-bph system was undertaken. During this process, decisions were made about which components and interactions to include in the computer model and the degree of detail with which these interactions were to be modelled. The major components and interactions considered in the first phase of the computer modelling process are shown in an interaction matrix (Fig. 1). These interactions concern bph population dynamics; subsequently, interactions related to management activities and regional climate will be incorporated.

Computer simulation

In the first phase of modelling, the following were direct inputs of field data for specific sites in the Philippines:

bph immigration rate,  
 predator density,  
 rate of bph parasitism,  
 white back planthopper and green leafhopper densities,  
 crop growth stage,  
 bph adult morph determination.

From these data, bph density was simulated using explicit relationships from the literature (for full details of relationships and sources see Holt et al., 1986). Relationships included were the effects of:

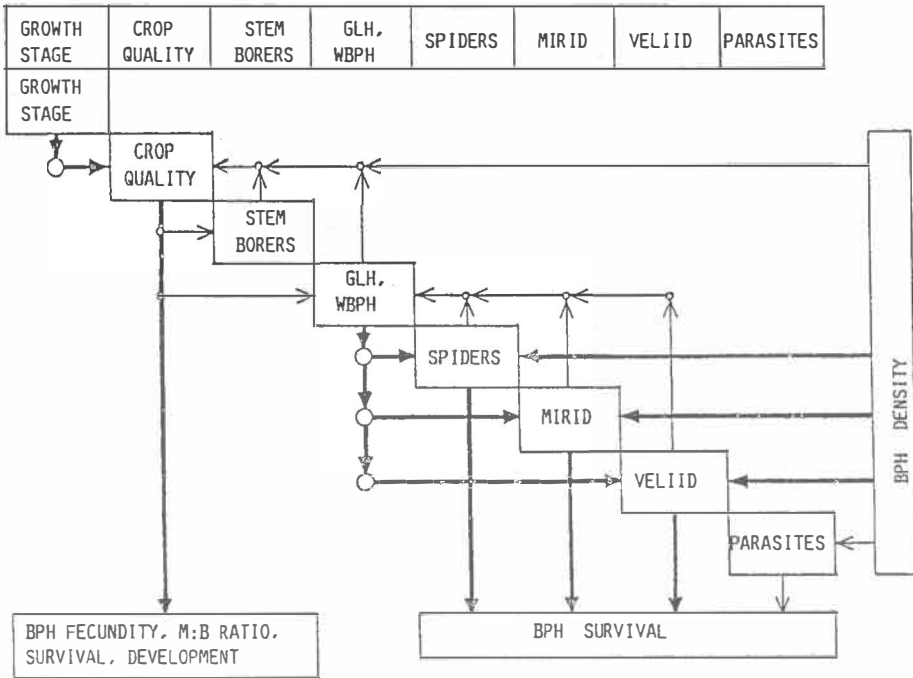

Fig. 1 Major interactions between brown planthopper, the rice crop and other crop fauna: effects explicitly included in the model (↔), other effects (→). Key: BPH, brown planthopper; GLH, green leafhopper; WBPH, whiteback planthopper; M:B RATIO, bph adult morph ratio

crop stage and hopper density on bph reproduction and survival,  
crop stage on bph emigration,  
density dependent predation and parasitism of bph,  
effects of other hoppers as alternative prey.

Attempts were made to simulate bph densities over a range of plots having large differences on observed bph density (Fig. 2). In order to achieve the simulations as shown, it was necessary to increase observed immigration differences from an observed ratio of 1:4 between plots 15 and 31 to a ratio of 1:11. This raised some useful questions about our understanding of bph population dynamics.

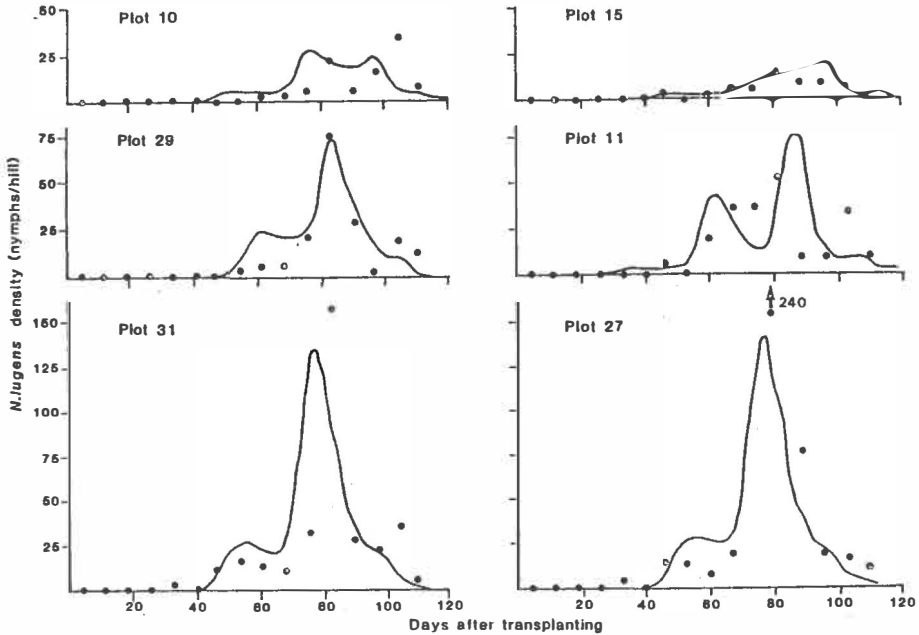

Fig. 2 Simulated (lines) and observed (dots) brown planthopper densities from six plots at the test site in Laguna Province, Philippines.

Essentially, simulated/observed discrepancies concerned the need to boost immigration differences, the pattern of early season population growth and the relative densities of the second and third generations. Possible reasons for the discrepancies included a lack of understanding of early-season predation, (possibly related to itinerant predators near boundaries), prey aggregation and prey exposure in open canopy, poor estimation of bph immigrant fecundity and mating success, and poor estimation of "turn-over" or emigration of macropters.

Model development

A number of discrepancies have been identified and can be investigated using sensitivity analysis, so improving confidence in the model as a reasonable hypothesis of bph populations dynamics. Obviously, this process is potentially open-ended and we suggest that the extent to which models are validated should depend on the modelling objectives (Fig. 3). Indeed, what constitutes a "discrepancy" or a "good fit" can only really be judged in terms of what questions we wish to address with the model.

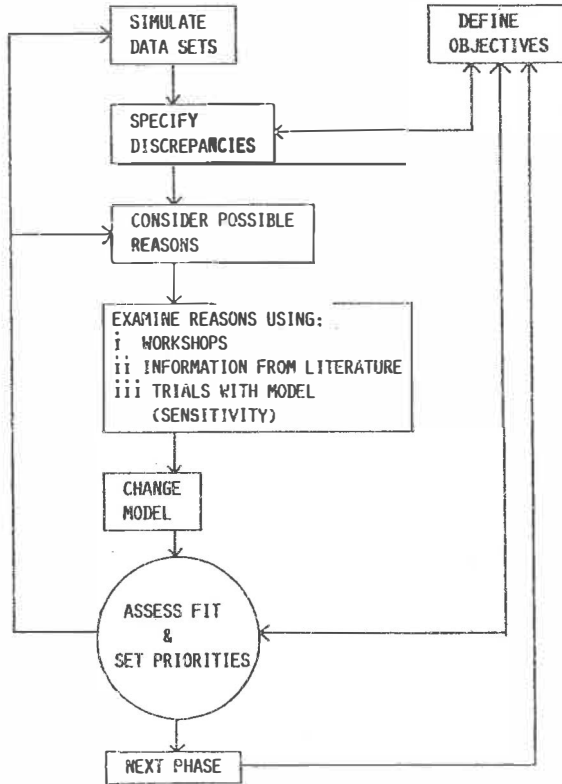

Fig. 3 Model development process. Rectangles represent activities; circles are decision points and arrows represent the sequence

The next phase of modelling, concerning the sensitivity of the model to its various components (Objective (1)) and the impact of management (Objective (2)) require a fully dynamic model, in which data inputs are replaced by functions, so that the model can respond to novel changes. The degree to which the model is validated before embarking on this phase will in part determine our confidence in the model as a reasonable hypothesis. If, however, the factors we are investigating have a fairly

gross impact on the model; (e.g. an insecticide application), a crudely validated model may provide an adequate hypothesis. The assessment of "model fit" and therefore the setting of priorities is largely therefore a question of objectives (Fig. 3).

#### References

Cook, A.G. & Perfect, T.J. (1985). The influence of immigration on population development of Nilaparvata lugens Stal and Sogatella furcifera Horvath and its interaction with immigration by predators. Crop Protection 4, 423-433.

Dyck, V.A., Misra B.C., Alam, S., Chen, C.N., Hsieh, C.Y. & Rejesus, R.S. (1979). Ecology of brown planthopper in the tropics. In Brown Planthopper Threat to Rice Production in Asia, IRRI, Los Banos, Philippines, pp. 61-68.

Holt, J., Cook, A.G., Perfect, T.J. & Norton, G.A. (1986). Simulation analysis of brown planthopper population dynamics on rice in the Philippines (in press).

Kenmore, P.E., Carino, F.O., Penez, C.A. Dyck, V.A. & Gutierrez, A. (1984). Population regulation of the rice brown planthopper within rice fields in the Philippines. Journal of Plant Protection in the Tropics 1, 19-37.

Perfect, T.J., Cook, A.G. & Ferrer, E.R. (1983). Population sampling for planthoppers, leafhoppers and their predators in flooded rice. Bulletin of Entomological Research 73, 345-355.

## HEAT ACCUMULATION FOR TIMING GRAPEVINE MOTH CONTROL MEASURES

V. Caffarelli and G. Vita

ENEA, Agro-Biotechnology Unit, 00198 Rome, Italy

### Introduction

The grapevine moth, Lobesia botrana Schiff., is the most important insect pest of vineyards in the Mediterranean area. The development of a sex pheromone trap has improved the timing of spraying to control this pest. Since traps measure only insect activity, which may be influenced by a number of environmental conditions, attempts to correlate the density and phenology of the pest to catches in the traps often fail. In this study we used calculation and summation of "degree-days" as indicators of grapevine moth phenology.

### Working methods

The study was performed in a vineyard area in the province of Rome. Male moths were monitored at least three times each week, from April through September, by means of synthetic sex pheromone traps. A hygrothermograph in the experimental area recorded temperatures. Temperature data relayed from the Rome airport weather station, 20 km away, were also recorded.

Starting on 1 January, daily maximum and minimum temperatures were used to calculate degree-days between the development thresholds. The lower and upper thresholds, determined from laboratory trials and from a literature search, were defined as 10°C and 30°C (Gabel, 1981; Gabel et al., 1984; Touzeau, 1980; Yersin, 1976). On the same basis, the development rate of the insect population was assumed to be linearly related to the temperature range between the lower and upper thresholds.

Cumulative degree-days were calculated using the sine method which uses a day's maximum and minimum temperature to produce a sine curve over a 24 h period. The cumulative heat in a day is estimated by calculating the sine area between the lower and upper thresholds.

### Results and Discussion

Because there were no significant differences between temperatures in the field and at the airport weather station, airport temperatures were used for the calculations. Cumulative degree-days in relation to adult male capture and oviposition, recorded from 1981 through 1985, are given in Table 1.

The discrepancy between the forecast cumulative degree-days for the phenological stages (Table 1) and the actual values for insect stages is shown in Table 2.



Table 1 Cumulative degree-days for three grapevine moth generations

	Year					Mean
	1981	1982	1983	1984	1985	
<b>First generation:</b>						
First catches	153	178	148	134	138	150
Flight peak	206	240	236	255	241	236
First eggs	-	-	328	273	-	301
<b>Second generation:</b>						
First catches	684	726	642	691	754	699
Flight peak	741	835	750	763	820	782
First eggs	-	-	725	752	705	727
100% hatch	900	-	884	835	857	869
<b>Third generation:</b>						
First catches	1293	1292	1295	1275	1388	1309
Flight peak	1465	1530	1546	1347	1422	1462
First eggs	-	-	1363	1312	1237	1304
100% hatch	1624	-	1580	1550	1563	1579

Table 2 Discrepancy (days) between actual and predicted dates of three grapevine moth generations

	Year					Mean
	1981	1982	1983	1984	1985	
<b>First generation:</b>						
First catches	0	7	0	-4	-3	2.8
Flight peak	-6	1	0	3	1	2.2
First eggs	-	-	4	-5	-	4.5
<b>Second generation:</b>						
First catches	-1	2	-5	-1	6	3.0
Flight peak	-3	3	-3	-2	3	2.8
First eggs	-	-	0	2	-2	1.3
100% hatch	3	-	1	-2	-1	1.7
<b>Third generation:</b>						
First catches	-1	-1	0	-3	5	2.0
Flight peak	0	4	5	-9	-3	4.2
First eggs	-	-	4	1	-5	3.3
100% hatch	3	-	0	-2	-1	1.5

In spite of the limited biological data upon which this method has been based, spray timing using the approach appears to be sufficiently accurate to warrant further study. Considering the unusual weather pattern of 1983 and 1984, this is encouraging.

This empirical phenological model could be of advantage in grapevine moth management programs, particularly in relation to the timing of chemical treatments. For example, the degree-day value which corresponds to observation of the first eggs provides a reference point at which to begin evaluating a chemical treatment. Furthermore, when used in combination with trap indications the method could eliminate the uncertainty inherent in the traps themselves. Combined use of pheromone traps, data relayed from public weather stations and historical temperature data could yield better forecasting of the time to treat.

Finally, the use of an automatic electronic trap (presently under study at our laboratory), combined with a temperature sensor, makes possible the development of a computer-based field unit to aid in making decisions. However, the method needs to be evaluated in other vine-growing areas in order to detect its deficiencies.

#### References

Gabel, B. (1981). Effects of temperature on the development and reproduction of the grape moth Lobesia botrana Schiff. (Lepidoptera, Tortricidae). Anzeiger für Schädlingskunde Pflanzenschutz Umweltschutz.

Gabel, B. and Mocko, V. (1984). Forecasting the cyclical timing of the grape vine moth, Lobesia botrana (Lepidoptera, Tortricidae). Acta Entomologica Bohemoslovaca **81**, 1-14.

Touzeau, J. (1980). Etude des principaux parametres biotiques et abiotiques necessaires a l'etablissement d'un modhle d'evolution de l'euidemis de la vigne (Lobesia botrana Schiff.) pour la region Midi-Pyrenees. Avertissement agricoles et lutte integrie observations, travaux et mises au point realisis en 1978 et 1979, n.8, 5-23, Ministere de l'Agriculture Service de la Protection des Vegetaux.

Yersin, Y. (1976). Amelioration de la methode de privision pour la lutte contre le vers de la grappe (Lobesia botrana) en premihre generation. Travail de diplome, Institut d'entomologie de l'Ecole Polytechnique Federale de Zurich.

MODELLING PRINCIPLES IN RELATION TO THE EPIDEMIOLOGY OF  
BARLEY YELLOW DWARF VIRUS

D. Morgan and N. Carter

Rothamsted Experimental Station, Harpenden, Hertfordshire, AL5 2JQ, UK

P.C. Jepson

Departments of Biology and Chemistry, The University, Southampton,  
SO9 5NH, UK

Introduction

Barley yellow dwarf virus (BYDV) is a widespread disease of cereals and grasses dispersed by aphids which feed on these host plants. It is a problem in England in early-sown winter cereals, especially barley, with infection of newly-emerged crops occurring in September and October. This can occur either as a carry over, via aphids from the previous cereal crop or its grass weeds, or from infective winged (alate) aphids, especially *Rhopalosiphum padi*, migrating to crops. The former is a local field problem and is not considered further in this study. An indication of the latter is obtained from the Infectivity Index. This Index is the product of the number of alate cereal aphids caught in the Rothamsted Insect Survey 12.2 m high suction traps (Taylor, 1979) and the proportion carrying virus (Plumb *et al.*, 1981). It is accumulated from the time of sowing and if it exceeds a threshold of 50 (Rothamsted area only) then the risk of damage is likely to warrant chemical control with an insecticide in late October or early November. This treatment is aimed at preventing the secondary spread of BYDV by the offspring of the immigrant aphids. Moreover, little is known about the factors which determine the speed and extent of this secondary spread.

Systems analysis has proved a useful approach in the study of pest problems and how to manage them (Ruesink, 1976) but it has been infrequently used for investigating insect-spread plant viruses, possibly because of the complexity of the system which involves plant, virus and insect (Carter, 1986). The advantage of systems analysis is that it is an organised approach involving a clear definition of the objectives and the use of mathematical techniques to investigate and experiment with models of the system.

Statistical models have been used for predicting virus diseases, for example sugar beet yellowing viruses (Watson *et al.*, 1975), and can reveal interesting relationships requiring further study. Frequently, however, as long as they forecast accurately these models are used without additional biological study of the processes involved, as was the case with sugar beet yellowing virus forecasts in the mid 1970s (Heathcote, 1986; Jepson and Green, 1983). Analytical models can be solved mathematically and are therefore easier to work with; however, they are usually too general for specific pest problems (Rabbinge & Carter, 1983). Simulation modelling is a technique which has been useful in studying biological systems, such as pest problems (de Wit & Goudriaan, 1978). In contrast to statistical models, which do not necessarily use causative relationships, simulation models attempt to explain processes and hence increase understanding (Rabbinge & Carter, 1983). They usually incorporate many variables, which can make analysis and interpretation difficult.

### The modelling process

Several interdependent steps are involved in the development and use of a simulation model (Carter, 1986).

The obvious first step in modelling is to define clearly the objectives of the study as they determine the type of model to be constructed, the precision of data required and the criteria to be used in evaluating the model. The availability of resources also plays an important part; if money, labour or equipment is limiting then the objectives and consequently the type of model to be produced will be influenced. A balance has to be reached between the data which can be collected and the complexity of model that can be developed.

The second step is to describe the system by listing all the components which the modeller feels might be important. This list should be dynamic, i.e. components are added and deleted throughout the study. Interactions between these components are usefully presented in relational diagrams in which variables are classified into five types (de Wit & Goudriaan, 1978): (i) state variables, which characterize and quantify properties which describe the state of a system, e.g. insect numbers, (ii) driving or forcing variables, which influence the system from outside but are not themselves affected by it, e.g. temperature, (iii) rate variables, which quantify the rate of change of state variables, e.g. reproduction, (iv) intermediate or auxiliary variables, which aid calculations carried out in the model, e.g. physiological time (which is a product of time and temperature), and (v) output variables, which are chosen by the modeller to fulfil the objectives of the modelling exercise. Interactions between these variables involve either a flow of biological material, e.g. numbers of insects moving from one instar to the next, or of information, i.e. the effect of one variable on another, so this distinction should be recognised when drawing relational diagrams.

The third step is to turn the descriptive model into a mathematical one by quantifying the interactions that have been described. Variable-life-table models, which are particularly useful in aphid studies because the presence of overlapping generations is assumed (Frazer, 1977), are comprised of at least three population processes: (i) development, (ii) survival, and (iii) reproduction, and possibly also migration, predation and parasitism. Insects are moved through age classes (development), with the loss of some individuals (mortality-survival) until the adult stage when they will start to produce new insects (reproduction). For virus diseases, transmission and acquisition periods also have to be taken into account and a crop development model incorporated to simulate the effects of different times of infection on virus spread and subsequent yield loss.

It is during model formulation that gaps in understanding are exposed, leading to further experimentation to fill them. Sensitivity analyses, (changing the value of parameters), are carried out at this stage and determine the precision with which these data need to be collected. If a small change in a parameter value, e.g. the number of offspring produced per unit of physiological time per female, results in a large change in predictions, then the value of that parameter needs to be known accurately. Conversely, if the effect is small then great precision is not vital.

Once a model has been formulated it has to be verified and validated before it can be used experimentally or as an advisory aid. Verification is the checking for computing errors in a program to ensure it is operating on the input data in the intended way. Validation is

the quantitative comparison of model predictions with data not used in the development of the model. Although some statistical tests have been used to validate models (Shannon, 1975), the most common way is by visual comparison of model output with data, together with associated limits, using graphs. It is important that validation is carried out over as wide a range of conditions as possible to test the robustness of the model (Barlow & Dixon, 1980).

Validation of a model is never completed but once a modeller is confident that the model is sufficiently accurate for the objectives of the study it can be used experimentally. Further sensitivity analyses can be made, perhaps changing more than one parameter at a time as in a replicated field experiment (Carter, 1986). Obviously the more parameters in a model the greater the potential number of simulations which can be made to study all interactions, and this is where problems of interpretation arise. The objectives of the study will largely determine the parameters of major interest.

#### Modelling the epidemiology of BYDV

The current modelling exercise aims to improve the precision of decision making to control BYDV by forecasting the degree of secondary virus dispersal. No attempt is being made to forecast the regional distribution of primary infection within a season or the extent of infection between years, although these may form later stages of the research programme. The initial model of within-field dispersal will be tested in field experiments and will be adapted for use in an interactive computer advisory package (Mann et al., 1987).

The first two steps in the modelling process, (i) the definition of objectives, and (ii) a description of the system, are described below.

There are four objectives of the study, (i) to gain greater understanding of the within-field epidemiology of BYDV, especially how the aphid, virus and crop interact, (ii) to expose gaps in knowledge and to stimulate further research, (iii) to develop simulation modelling as a useful technique in the study of virus diseases, and (iv) to develop improved advisory packages that modify regional advice with field specifications.

Fig. 1 is a simplified conceptual diagram of the system. Primary infection of a newly emerged crop is assumed to occur solely from infected alates migrating in the autumn. It is likely that their offspring will be infected by feeding on these plants prior to their dispersal. Available data (Dean, 1974; van der Broek & Gill, 1980; Watson & Mulligan, 1960) suggest that the initial virus transmission period, the latent period before the plant becomes infective and the acquisition period, are much shorter than the developmental period of the aphids. This assumes that plants remain consistently infective over the winter period whereas there is some evidence of cycles in infectivity when the plants are actively growing (Gill, 1969).

Very little experimental work on aphid population development or virus transmission has been carried out at temperatures experienced during the autumn (for example Rothamsted mean October minimum temperature is 6.5°C, and mean maximum temperature is 13.9°C (Anon., 1985). The laboratory studies of Dean (1974), in which the lowest temperature used was 10°C, provides a starting point for the aphid development submodel.

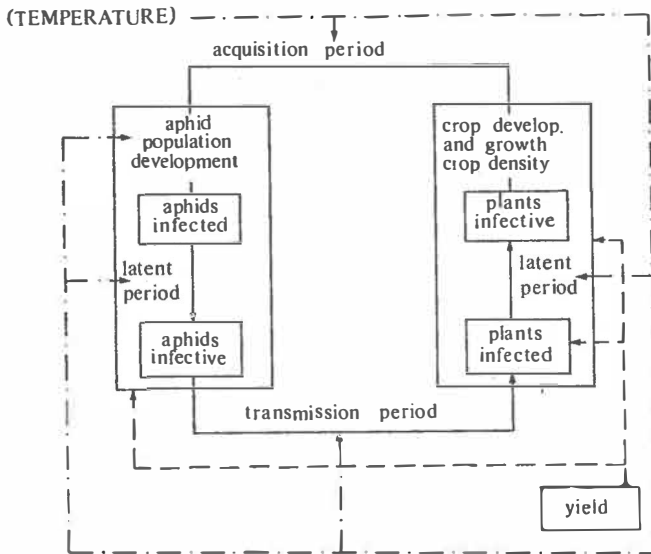

Fig. 1. Conceptual diagram of the BYDV system

The data on developmental rate (Y) and temperature (X) yields the relationship:

$$Y = 0.00038X - 0.00107. \quad (r = 0.997, \quad n = 4)$$

with a threshold temperature of 2.8°C. This relationship is unlikely to remain linear over the entire range but until more data become available it will be used in the model. Field studies indicate that *R. padi* is the least cold-hardy of the commoner cereal aphids (Dewar & Carter, 1984; Williams, 1980), which would indicate that in Eastern England it is unlikely to be important, in most years, in spreading the virus after January. It is hoped that the modelling exercise will substantiate this view by simulating aphid population development and dispersal over a range of temperatures to initiate annual and regional variations.

#### References

- Anon. (1985). Weather tables. Rothamsted Report for 1984, p. 318.
- Barlow, N.D. and Dixon, A.F.G. (1980). Simulation of Lime Aphid Population Dynamics. Pudoc, Wageningen, The Netherlands.
- van der Broek, L.J. and Gill, C.C. (1980). The median latent period for three isolates of barley yellow dwarf virus in aphid vectors. Phytopathology 70, 644-646.

- Carter, N. (1986). Simulation modelling. In: Plant Virus Epidemiology: Monitoring, Modelling and Predicting Outbreaks. (McClellan, G.D., Garrett, R.G. and Ruesink, W.G., eds.) pp. 193-215, Academic Press, Sydney.
- Dean, G.J. (1974). The effect of temperature on the cereal aphids Metopolophium dirhodum (Wlk.), Rhopalosiphum padi (L.) and Macrosiphum avenae (F.) (Hem., Aphididae). Bulletin of Entomological Research **63**, 401-409.
- Dewar, A.M. and Carter, N. (1984). Decision trees to assess the risk of cereal aphid (Hemiptera : Aphididae) outbreaks in summer in England. Bulletin of Entomological Research **74**, 387-398.
- Frazer, B.D. (1977). Plant virus epidemiology and computer simulation of aphid populations. In: Aphids as Virus Vectors. (Harris, K.F. and Maramorosch, K. eds.) pp. 413-431, Academic Press, New York.
- Gill, C.C. (1969). Cyclical transmissibility of barley yellow dwarf virus from oats with increasing age of infection. Phytopathology **54**, 23-28.
- Heathcote, G.D. (1986). Virus yellow of sugar beet. In : Plant Virus Epidemiology: Monitoring, Modelling and Predicting Outbreaks. (McClellan, G.D., Garrett, R.G. and Ruesink, W.G. eds.) pp. 339-417, Academic Press, Sydney.
- Jepson, P.C. and Green, R.E. (1983). Prospects for improving control strategies for sugar beet pests in England. In: Advances in Applied Biology. (Coaker, T.H. ed.) Vol. 7, pp. 175-250, Academic Press, London.
- Mann, B.P., Wratten, S.D. and Watt, A.D. (1987). A computer-based advisory system for cereal aphid control. Computers and Electronics in Agriculture (in press).
- Plumb, R.T., Lennon, E.A. and Gutteridge, R.A. (1981). Barley yellow dwarf virus. Rothamsted Report for 1980. Part 1, p. 182.
- Rabbinge, R. and Carter, N. (1983). Application of simulation models in the epidemiology of pests and diseases; an introductory review. In: The Development of Models for Practical Use in Crop Protection (M.J. Jeger, ed.). Bulletin of the IOBC (WPRS) V1/2, 18-30.
- Ruesink, W.G. (1976). Status of the systems approach to pest management. Annual Review of Entomology **21**, 27-44.
- Shannon, R.E. (1975). Systems Simulation: The Art and Science. Prentice-Hall, Eaglewood Cliffs.
- Taylor, L.R. (1979). The Rothamsted Insect Survey - an approach to the theory and practice of synoptic pest forecasting in agriculture. In: Movement of Highly Mobile Concepts and Methodology in Research. (Rabb, R.L. and Kennedy, G.G. eds.) pp. 148-185. North Carolina State University.
- Watson, M.A., Heathcote, G.D., Lauckner, F.B. and Sowray, P.A. (1975). The use of weather data and counts of aphids in the field to predict the incidence of yellowing viruses to sugar beet crops in England in relation to the use of pesticides. Annals of Applied Biology **81**, 181-198.

Watson, M.A. and Mulligan, T. (1960). The manner of transmission of some barley yellow-dwarf viruses by different aphid species. Annals of Applied Biology 48, 711-720.

Williams, C.T. (1980). Low temperature mortality of cereal aphids. Bulletin of the IOBC (WPRS) III/4, 63-66.

de Wit, C.T. and Goudriaan, J. (1978). Simulation of Ecological Processes. Pudoc, Wageningen, The Netherlands.



USE OF A TIME-VARYING DISTRIBUTED DELAY MODEL FOR SIMULATING  
THE FLIGHT PHENOLOGY OF THE SUMMERFRUIT TORTRIX (ADOXOPHYES ORANA)  
IN THE VALAIS, SWITZERLAND

J. Baumgärtner and J.-J. Favre

Institut de Phytatrie EPF, CH-8092 Zurich, Switzerland

A.Schmid

Station Protection des Plantes, CH-1950 Chateauneuf-Sion, Switzerland

Introduction

The study of recurring biological events and of their causes is called phenology (see Lieth, 1974) and has two objectives when developing integrated pest management programs. Welch et al. (1978) use phenology models to define critical periods in pest development for making management decisions, while Baumgärtner and Charmillot (1983) constructed a phenology model primarily to improve what we know of the life system of Adoxophyes orana F.v.R. in Swiss apple orchards. The latter authors considered that good knowledge of ecological processes is an important prerequisite for developing integrated pest management programs (Baumgärtner, 1985). In work described here, an improvement of the research tool of Baumgärtner and Charmillot (1983) is attempted by making the model more realistic with respect to the experimental data base used to construct it. In addition, the model is adapted to local conditions of the Valais for monitoring A. orana development in supervised pest control programs.

Materials and methods

Time invariant distributed delays have been widely used to simulate insect phenologies and population dynamics (Baumgärtner, 1985; Baumgärtner & Charmillot, 1983; Croft & Knight, 1983; Gutierrez et al., 1984; Welch et al., 1978). In these models time is generally expressed in physiological units of daydegrees which reflect a linear relationship between developmental rates of poikilothermic organisms and temperature (Gilbert et al., 1976). In this work, however, a non-linear model for relating developmental rates  $r_j$  of immature life stages  $j$  (eggs, larvae, pupae, overwintering larvae) to the temperature  $T$  above a lower threshold  $To_j$  is presented in Equation 1 (see Harcourt & Yee, 1982)

$$r_j = 0 \quad \text{for } T \leq To_j \quad [1]$$

$$r_j = a_j + b_j \cdot T + c_j \cdot T^2 \quad \text{for } T > To_j$$

and the rates  $r_j$  are combined with the time-varying distributed delay model detailed by Manetsch (1976). For adults only, a linear model is used for describing the developmental rate - temperature relationship (Equation 2)

$$r_4 = 0 \quad \text{for } T \leq To_4 \quad [2]$$

$$r_4 = 0.00526 \quad \text{for } T > To_4$$

The parameters  $a_j$ ,  $b_j$ ,  $c_j$  and the stage specific developmental threshold are presented in Table 1, while details of diapause induction and reproduction are given by Baumgärtner and Charmillot (1983). A time step of 2.4 hours is used and mean temperatures for each step are calculated by forcing a cosine wave through daily maximum and minimum temperatures (see also Flückiger & Benz, 1982).

Table 1. Parameter estimation for the time-varying distributed delay model for simulating the flight phenology of *Adoxophyes orana* ( $D_j$  = developmental time in daydegrees for the linear model;  $To_j$  = lower developmental threshold;  $r_j$  =, temperature dependent developmental rates per day).

Life stage	j	$D_j$	$To_j$	$r_j$
eggs	1	94.4	9.4	$-0.08963 + 0.00926.T + 0.00004.T^2$
larvae	2	339.1	7.1	$-0.01387 + 0.00178.T + 0.00004.T^2$
pupae	3	84.5	11.1	$-0.15431 + 0.01469.T + 0.00008.T^2$
adults	4	190.1	11.1	$1/D_4$
overwintering larvae	5	$D_2 \cdot 0.69$	7.1	$r_2 \cdot 1.45$

The flight of *A. orana* was recorded with pheromone traps from 1979 to 1984 near Sion, Valais, and the cumulative flight intensities, which are expressed as proportions of the total catch in a given generation of a particular year, are used for constructing and validating the model. Because both the characteristics of the larval diapause and the age structure of the larvae at the beginning of the year are unknown, developmental rates for overwintering larvae are estimated by minimising the difference in daydegrees (see Equation 2) between the observed and predicted emergence of 50% of the adults. The calculated ratio of larvae entering diapause in the first generation after overwintering varies between 12% and 0% in the six years under study, but to facilitate comparisons with pheromone trap catches the calculated flight ratios are expressed as proportions of the total number of moths emerging in generation 2 (Figs. 1, 2 and 3). While the cumulative flight intensities for 1983 are given in Fig. 1, predicted and observed ratios for each year under study are plotted in Figs. 2 and 3 for visual model evaluation.

### Results and Discussion

The time-varying distributed delay model enabled consideration to be given to non-linear developmental rates with respect to temperatures (Equation 1). In the earlier version, a linear model was used and combined with a time-invariant distributed model (Baumgärtner & Charmillot, 1983). Because a non-linear model corresponds better to the experimental background (Baumgärtner & Charmillot, 1983) the new model is considered more realistic. Unfortunately, developmental rates were measured at three temperatures only and parameterization of the polynomial model proposed by Harcourt and Yee (1982) is difficult. Additional experiments particularly at high temperatures may provide a more satisfactory description of the developmental rate - temperature relationship and are likely to improve the model further.

According to Fig. 1 the model accurately represents both the first and second flight in 1983. In addition the model predicts a third flight that was not always as conspicuous as in this year. The calculated beginning of this flight, however, is generally later than the last pheromone catches in all six years under study and there are no other observations available for confirming it. This flight is not important from a practical standpoint.

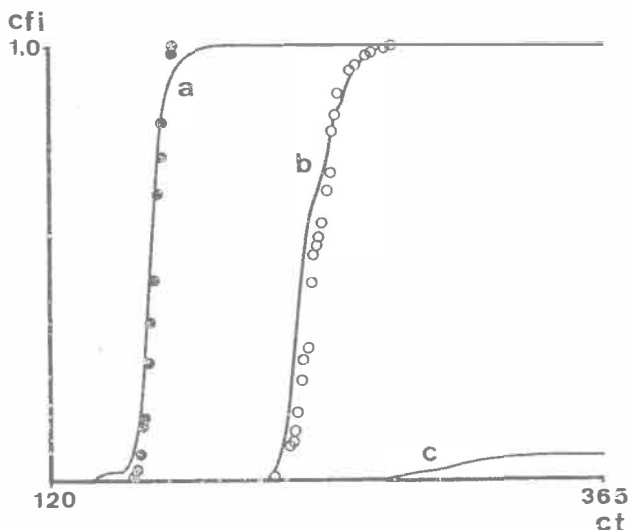

Fig. 1 Cumulative flight intensity (cfi) of *Adoxophyes orana* at Sion, Switzerland, as observed in pheromone traps (O ●) and as predicted by the simulation model (a = first; b = second; c = third flight; ct = calendar time) for 1983.

A steep increase of emergence of moths in Fig. 1 coincides with high variances, and discrepancies between observed and calculated flight intensities at peak flight in Figs. 2 and 3 are likely to be overestimated by this validation procedure. In general, the first and the beginning of the summer flight are satisfactorily simulated by the model in all 6 years, but the following flight patterns are not always as well represented by the model as in 1983 (Figs. 1, 2 and 3). This is not unexpected because many factors which are known to influence phenologies are not built into the model, as yet. Among them there are fluctuating temperatures, microclimatic conditions and spatial distribution patterns of *A. orana*, trophic influences and larval development, mortalities and adult behaviour (Baumgärtner & Charmillot, 1983; Flückiger & Benz, 1982; Gutierrez et al., 1984; Messenger, 1959; Vansickle, 1977), but actual knowledge does not permit testing them in this model. These gaps are therefore seriously limiting its use for research purposes.

The results obtained so far indicate that monitoring the development of *A. orana* in the orchards of the Valais may become more efficient. The extension service may appreciate that age structure is incorporated into the model which enables simulation also of hatching of eggs. This ability is important for timing insecticide applications. The model, however,

does not generate population densities, which are required when justifying chemical control measures in integrated pest management programs. Despite this problem, the measure is considered a useful trap management tool which may become more reliable if future pheromone trap catches confirm its validity.

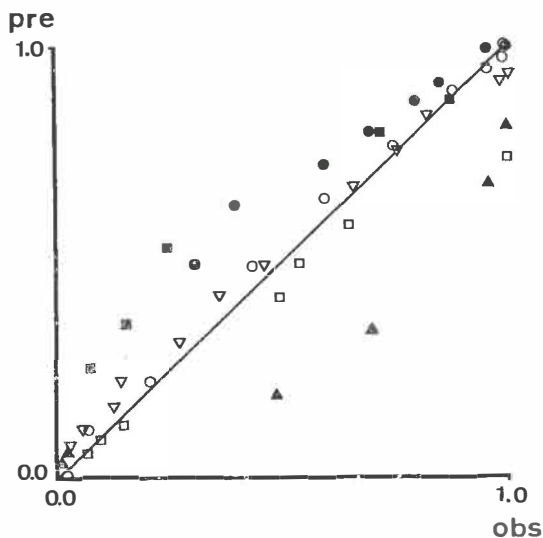

Fig. 2. Cumulative flight intensity for the first flight of *Adoxophyes orana* in an orchard of the Valais as predicted by the model (pre) and observed in pheromone traps in 1979 (○), 1980 (◼), 1981 (●), 1982 (◻), 1983 (▽), and 1984 (▲). Each symbol represents one or more data points.

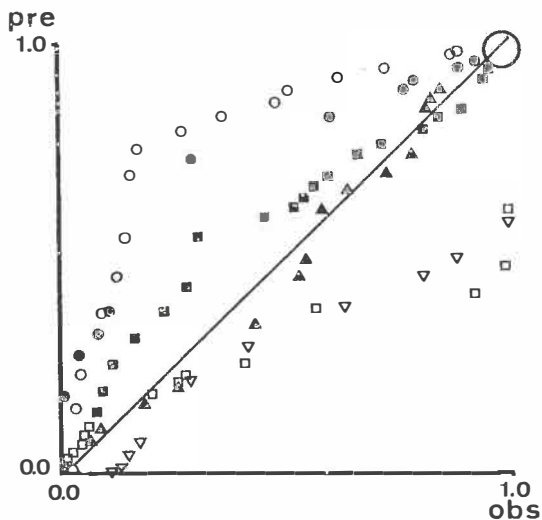

Fig. 3. Cumulative flight intensity for the second flight of *Adoxophyes orana* in an orchard of the Valais as predicted by the model (pre) and observed in pheromone traps in 1979 (○), 1980 (◼), 1981 (●), 1982 (◻), 1983 (▽), and 1984 (▲). Each symbol represents one or more data points.

### Acknowledgements

The authors wish to thank Prof. Dr. V. Delucchi, Institut de Phytiatrie EPF, Zurich, for critically reviewing the manuscript. Dr W. Berchtold, Institut für Tierproduktion ETH, Zurich kindly advised on validation procedures.

### References

Baumgärtner, J. (1985). Übersicht über die Analyse des Apfelbaumökosystems in der Schweiz. Schweiz. Landw. Fo. 24, 27-44.

Baumgärtner, J. & Charmillot, P.J. (1983). An analysis of the summer fruit tortrix (Adoxophyes orana F.v.R.) flight phenology. Zeitschrift für angewandte Entomologie 95, 405-413.

Croft, B.D. & Knight, A.L. (1983). Evaluation of the PETE phenology system for integrated pest management of deciduous tree fruit species. Bulletin of the Entomological Society of America 29, 37-42.

Flückiger, C.R. & Benz, H. (1982). A temperature-driven model to simulate the population development of the summerfruit tortrix, Adoxophyes orana. Entomologia experimentalis & applicata 32, 161-172.

Gilbert, N., Gutierrez, A.P., Frazer, B.D. & Jones, R.E. (1976). Ecological relationships. W.H. Freeman, Reading, 157 pp.

Gutierrez, A.P., Baumgärtner, J. & Summers, C.G. (1984). Multitrophic models of predator-prey energetics. Canadian Entomologist 116, 923-963.

Harcourt, D.G. & Yee, J.M. (1982). Polynomial algorithm for predicting the duration of insect life stages. Environmental Entomology 11, 581-584.

Lieth, H. (1974). Purposes of a phenology book. In Lieth, L. (Ed.) Phenology and seasonality modelling, pp. 3-19, Ecological Studies 8, Springer-Verlag, Berlin.

Manetsch, T.J. (1976). Time-varying distributed delays and their use in aggregative models of large systems. IEEE Transactions of Systems Man. and Cybernetics 6, 547-553.

Messenger, P.S. (1959). Bioclimatic studies with insects. Annual Review of Entomology 4, 183-206.

Vansickle, J. (1977). Attrition in distributed delay models. IEEE Transaction Systems Man. and Cybernetics 7, 635-638.

Welch, S.M., Croft, B.A., Brunner, J.F. & Michels, M.F. (1978). PETE: an extensive phenology modelling system for management of multi-species pest complex. Environmental Entomology 7, 482-494.

FORECASTING DISEASES OF AGRICULTURAL CROPS IN WESTERN GERMANY

A. Obst

Bayerische Landesanstalt für Bodenkultur und Pflanzenbau,  
Postfach 380269, 8 München 38, Federal Republic of Germany

Introduction

The aim of every disease intelligence system is to recognise plant disease epidemics at an early stage, when they can still be controlled successfully. In the Federal Republic of Germany two models for forecasting plant diseases are at present helping farmers to decide on the economic and timely use of fungicides.

Eyespot of winter wheat (*Pseudocercospora herpotrichoides*)

*P. herpotrichoides* is a soil-borne pathogen with very limited spread. Since inoculum levels are different from field to field and cannot be assessed directly, it is practically impossible to develop a forecast method based on this variable.

A second characteristic of this pathogen is its development which is slow with only a few generations per year and highly dependent on meteorological conditions. Since 1974, the system CERCPROG, which has been developed by Schrödter & Fehrmann (1971), is operated by the official meteorological service. It tries to define by meteorological parameters periods which are favourable for mass infections. Prior conditions required for this method are (i) an infection pressure which is constant over time, and (ii) a homogenous distribution of inoculum sources. This means that the system is valid only for infections in spring, after the pathogen has built up its infection potential step by step. As a rule infections in spring are of general importance, whereas those from the autumn are significant only in specific conditions of crop rotation.

Schrödter & Fehrmann have defined the influence of weather variables on sporulation of *Pseudocercospora* and on infection of young wheat plants. The amount of infection in the field is determined essentially by three meteorological parameters:

- (i) temperature (optimum for sporulation 3-4°C, for infection 8-9°C)
- (ii) humidity of the air ( $\geq 80\%$  in a standard weather station)
- (iii) duration of periods with favourable conditions of temperature and humidity (4-13°C, relative humidity  $\geq 80\%$ ).

Other factors such as the intensity of rainfall and wind velocity are of less importance. By means of multiple regression analysis the frequency of specific climatic criteria has been related to disease observations to produce a prognosis system.

From about 80 weather stations in Western Germany, temperature and humidity data are recorded every hour. Once each week they are fed into the control computer at Offenbach. The prognosis for a particular date is based on meteorological data of the past 3 weeks (Fig. 1 (Freitag, 1977)). The output is the "infection probability due to meteorological

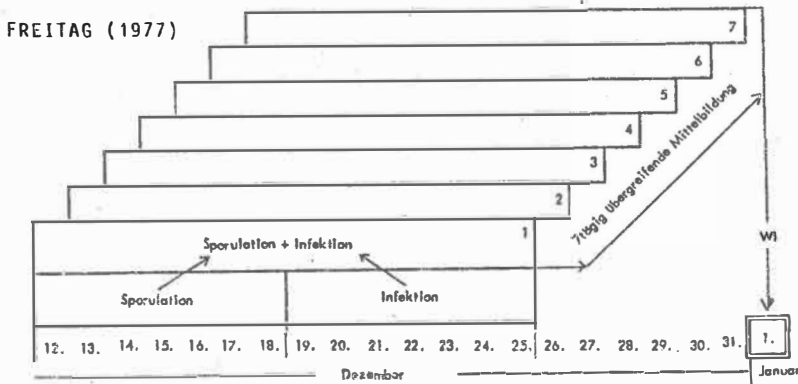

Fig. 1. Final ordering of weather conditions influencing infection probabilities

conditions". The prognosis data of different weeks are presented as a graph (Fig. 2). By this method the infection of young wheat plants in the years 1966-68 could be predicted with a coefficient of determination ( $R^2$ ) = 0.72.

Herausgegeben vom Deutschen Wetterdienst,  
Abteilung Agrarmeteorologie, Offenbach

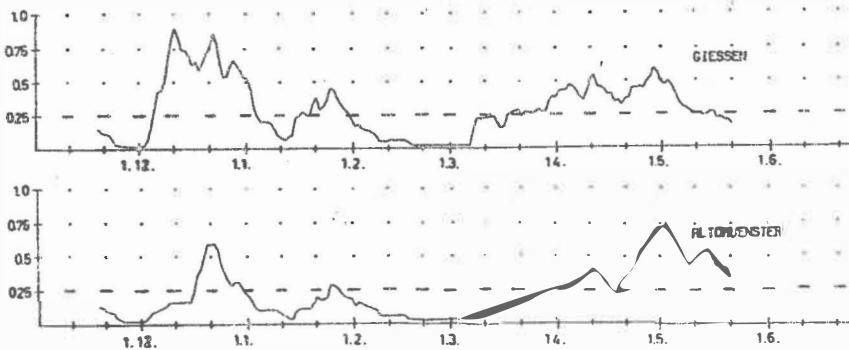

Fig. 2. Infection probability for P. herpotrichoides in a winter wheat crop, 19 May 1986.

Evaluation of the method. There are no critical periods of infection sharply limited in time; however, there are periods with low and with high infection probability. Also, the method was developed only for young wheat plants. It is likely that the susceptibility of wheat differs at different growth stages. The progress of the pathogen within the host plant is not included and the model does not define a control threshold.

Nevertheless, the German advisory service considers this method of eyespot prognosis to be useful to evaluate past weather periods in terms of eyespot infections.

Recently, Weihofen et al. (1986) have improved the model from data acquired in the field with a data logger. The regression model has been elaborated and is now composed of the following calculations:

- (i) disease level due to agronomic factors, such as pH of the soil, sowing date and degree of tillering at the end of winter,
- (ii) infection probability due to weather parameters (favourable conditions are relative humidity  $\geq 80\%$  between 4-10°C)
- (iii) date of the first significant infection after seedling emergence
- (iv) development of the pathogen within the host plant according to daily mean temperatures
- (v) decision for or against a fungicide treatment.

The model has been evaluated on a broad scale since 1985.

#### Potato late blight (*Phytophthora infestans*)

Since 1967, PHYTPROG, which has been developed by Schrödter & Ullrich (1967) has been in operation. The system estimates the length of time between the occurrence of the initial inoculum source (the first diseased shoot at potato emergence) and the onset of an epidemic. This forecast approach is particularly appropriate for plant diseases which have low primary inoculum levels and high infection rates closely related to weather.

By means of multiple regression analysis, five biometeorological parameters have been assembled which relate late blight occurrence to environmental conditions. These are:

- (i) meteorological influence on sporangium production (at least 10 hours with a relative humidity  $\geq 90\%$ , or rain  $\geq 0.1$  mm/h)
- (ii) meteorological influence on sporangium germination and infection (at least 4 hours with a relative humidity  $\geq 90\%$ , or rain  $\geq 0.1$  mm/h)
- (iii) meteorological influence on mycelium development in the host plant (only 15-20°C)
- (iv) magnitude and duration of favourable parameter combinations
- (v) effect of dry periods on disease development (no sporangium survival at relative humidities  $< 70\%$ )

Disease progress is calculated by means of a stress function, which sums up the frequency of specific meteorological combinations which are favourable for the three major stages of the pathogen's development, i.e. rates of sporulation, infection and lesion growth. Moreover, the influence of favourable and unfavourable weather conditions is included.

The PHYTPROG model calculates from the weather inputs the logit value of disease severity, the critical threshold values being 150 and  $270 \times 10^{-2}$  logits (0.1 and 1% disease severity, respectively). Since only meteorological and biological criteria are considered, the system cannot predict the real disease situation. It can only define blight-free



periods, i.e. the time after plant emergence up to which late blight will not occur. The model does not predict the onset of an epidemic. The term "negative forecast" is used to describe this type of approach.

The forecast system is based on weather data from 80 standard weather stations. Temperature, relative humidity of the air and the amount of rainfall are registered every hour, and once each week are collected and processed by the central computer at Offenbach. Experimental field evaluation give a coefficient determination between actual disease and disease prediction of 0.56.

Evaluation of the system. The entire variability and dynamics of weather have been incorporated into one complex model. However, the different relationships between meteorological parameters and disease development are considered in a relatively simple statistical model, which cannot of course give deep insights into the mechanisms of the host-pathogen-environment system.

The forecast conception was developed with a susceptible, early ripening potato variety (Erstling), but it applies also to new varieties under modern husbandry methods (Schiff & Schrödter, 1984). Good correlations between disease ratings of the system and actual disease occurrence have been observed mainly in Northern Germany. It is possible that the small number of weather stations in Southern Germany does not reflect the many disease situations which are widely different within small distances of each other.

#### References

- Freitag, E. (1977). Summen der Witterungsbedingten Infektionswahrscheinlichkeit. Ein Versuch, die Halmbruchkrankheit bei Winterweizen frühzeitig vorauszubeurteilen. Mitteilungen Biologische Bundesanstalt Land- Forstwirtschaft, Berlin-Dahlem, H. 178, 120-121.
- Schiff, H. and Schrödter, H. (1984). Untersuchungen über die Treffsicherheit der Negativ-Prognose zur zeitgerechten Bekämpfung der Kraut- und Knollenfaule der Kartoffel. Kali-Briefe 17, 163-172.
- Schrödter, H. and Fehrmann, H. (1971). Okologische Untersuchungen zur Epidemiologie von Cercospora herpetchoides. III. Die relative Bedeutung der meteorologischen Parameter und die komplexe Wirkung ihrer Konstellationen auf den Infektionserfolg. Phytopathologische Zeitschrift 71, 203-222.
- Schrödter, H. and Ullrich, J. (1967). Eine mathematisch-statistische Lösung des Problems der Prognose von Epidemien mit Hilfe meteorologischer Parameter, dargestellt am Beispiel der Krautfaule (Phytophthora infestans). Agricultural Meteorology 4, 119-135.
- Weihofen, U., Siebrasse, G. and Fehrmann, H. (1986). Ein Warnsystem für den Pflanzenschutz und seine Anwendung bei der Halmbruchkrankheit im Winterweizen. Mitteilungen Biologische Land- Forstwirtschaft, Berlin-Dahlem, H. 232, 125-126.

## CROP LOSS ASSESSMENT AND ECONOMIC INJURY LEVELS

R. Rabbinge

Department of Theoretical Production Ecology, Agricultural University  
Bornsesteeg 65, Wageningen, The Netherlands

### Introduction

Crop losses caused by pests and diseases are well documented, but the additional yield loss that may be expected at a particular disease severity or pest density is generally not well documented (Wood & Jellis, 1984). How various pests and diseases affect growth and production under various conditions is, in general, also not known. Estimates of yield loss due to pests or diseases are needed in any supervised or integrated control system. They constitute the basis for an economic cost-benefit analysis of control measures and thus help to develop rational crop protection systems. These yield losses may be expressed in kg product or economic value. Yield losses are often based on intelligent guesses by agronomists and crop protectionists; seldom are they based on knowledge of the nature and level of crop growth reduction due to the presence of pests and diseases (hereafter collectively referred to as pests). The increasing importance of pests as growth and production reducing factors (Smith *et al.*, 1984) justifies more detailed analysis of the interaction between the host plant (crop) and its enemies. This may be a statistical analysis of the relation in physical terms or in economic value between pest severity or infection level and crop loss. Much detailed and painstaking observation of pests and crop growth is required to determine growth and yield reductions due to their effects. In most studies of pest management the concept of Economic Injury Level (EIL) is introduced as the value at which the costs for control are in balance with the expected yield loss. Usually, control measures are needed long before this level is reached. Such an action threshold is widely used. However, the EIL concept, although revolutionary when it was introduced by Stern (1959), presumes a fixed relation between pest intensity and yield loss irrespective of crop growth conditions. Since these conditions may vary considerably, results may be variable.

Statistical approaches, as described by Daamen (1987) may be dynamic or static i.e. the concept of time may or may not occur in the calculations. In statistical approaches observations are done only at the systems level - the growing crop and the pest populations. Usually, crop growth and yield in field experimental plots with pests present are compared with plots in which pests are controlled. By repeating experiments in different years and at various places, a relation between yield depression and pest density can be determined.

### Single point, multiple point and the area under the disease/pest progress curve to determine EIL

Single point models and the area under the disease/pest progress curve are usually used to express pest intensity. In Table 1 some examples are given of equations which are used to translate pest intensity to yield loss in kg product or in money. Single point relations are most frequently used to relate yield loss to pest density. They are the easiest to derive but, since epidemics develop in time, they are normally very unreliable. In statistical terms, some improvement is often made with multiple point models.

Table 2. Some examples of equations based on single point, multiple point and area under the progress curve models, which relate percentage disease to yield loss (most from Smith et al., 1984).

Disease	Equation	Reference
<b>1. <u>Single point</u></b>		
<u>Septoria tritici</u> wheat	Y = -2.6943 + 0.6366 X X = % disease on foliage at GS 59	Eyal (1972)
<u>Puccinia graminis</u> wheat	Y = -25.53 + 27.17 log X X = % disease at GS 75	Romig & Calpouzos (1970)
<u>Pyricularia oryzae</u> rice	Y = 0.57 X X = % diseased plants 30 days after heading	Latsibe & Koshimizu (1970)
Cereal aphids	Y = 17.2 + 79.9 X = density aphids tiller <sup>-1</sup> at GS 75	Rabbinge & Mantel (1981)
<b>2. <u>Multiple point</u></b>		
<u>Rhynchosporium secalis</u> spring barley	Y = (0.66 X <sub>1</sub> + 0.50 X <sub>2</sub> ) 12 X <sub>1</sub> & X <sub>2</sub> = % disease on flag leaf & leaf 2 at GS 75	James <u>et al.</u> (1968)
<u>Puccinia recondita</u>	Y = 5.3788 + 5.526 X <sub>2</sub> - 0.3308 X <sub>5</sub> + 0.5019 X <sub>7</sub> X <sub>2</sub> = % disease on culms at GS 44 X <sub>5</sub> + X <sub>7</sub> = % disease on flag leaf at GS 75 and 85	Burleigh <u>et al.</u> (1972)
<u>Phytophthora infestans</u> potato (early infection)	Y = 1.867 X <sub>1</sub> + 0.446 X <sub>2</sub> + 1.144 X <sub>3</sub> + 0.628 X <sub>4</sub> + 0.193 X <sub>5</sub> + 0.180 X <sub>6</sub> (+0.0X <sub>7</sub> ) + 0.343 X <sub>8</sub> + 0.829X <sub>9</sub> where X <sub>1</sub> ...X <sub>9</sub> = % defoliation increments over 9 weeks	James <u>et al.</u> (1972)
<b>3. <u>Area under disease curve</u></b>		
<u>Cercospora</u> spp. cowpea	Area under curve of disease severity index (0-9) against time for at least 2 assessments from onset to harvest  % loss = 0.43 (Area) + 14.95	Schneider <u>et al.</u> (1976)
Cereal aphids	Aphid days against yield loss	Rabbinge & Mantel (1981)
Fruit tree red spider mite	Mite days against yield loss	Rabbinge (1985)

In multiple point models, pest density is determined at various moments of the pest progress curve and the values, often weighted according to a statistically determined factor, are related to yield loss. The advantages of this method are that some concept of the dynamics of the pest is incorporated and that the relative weight of various pest intensities in the course of time may be considered.

Another dynamic approach is the concept of the area under the disease/pest progress curve. Here the density of the pest or severity of disease is integrated in time and related to yield loss. The "load" of the pest on the growing crop is nowadays emphasised in studies on crop loss assessment and in supervised control schemes, such as EPIPPE. However, the implicit assumption that there are no "critical periods" may be invalid. In many cases, early or late attacks of the pest will have quite different effects on crop growth and yield. Shaw and Royle (1987b) take this into account by proposing essentially an improvement of "the area under the disease progress curve" method. They relate the disease present at every instant during the growth of the crop to the final yield, through a rate of yield loss function. By integration of this rate of yield loss an estimate of final yield loss is obtained. The data for such a function are obtained from yields and estimated disease progress curves in a set of field plots (Shaw & Royle, 1987a).

#### Dynamic programming to determine EILs

A method to determine the best timing of a control measure and the corresponding EIL is described by Onstad and Rabbinge (1985). They use dynamic programming, a method used in pest and disease management for the computation of EILs, and developed a deterministic dynamic programming algorithm for tactical decision-making in cereal aphid control. This algorithm was used to identify two discrete values of the state variable APHIDS, that describe the number of aphids per tiller, between which the control policy changed from no treatment to aphicide treatment. This is then defined as the EIL. By this procedure the estimated curves for dynamic EILs fall between several sets of two points. In Fig. 1 the symbols represent these calculated points, the curves are interpolations. By using narrower intervals between the discrete values of the state variables the range of these points could be reduced. The change in EIL between crop development stages is striking, even more so when yield levels are also considered. The above study was done for a yield level of  $8 \text{ t/ha}^{-1}$  of wheat, but would change with lower or higher yield levels.

#### Dynamic explanatory approaches

The methods described above may be used to estimate yield loss expectation. However, they are based on a description of the field situation. Although much information is analysed in detail, these methods do not give insight into the causes of damage. Extrapolation to unknown field conditions is therefore dangerous, as the consequences of the interaction between pest and crop may vary considerably and may result in a different yield loss - pest density relation. For example, weather conditions may not only affect the epidemiological development of a disease but also the host-pathogen relation (Zadoks & Schein, 1979). Besides time and place of the pest, the crop growing conditions may affect considerably the extent of yield reduction. At high leaf nitrogen levels

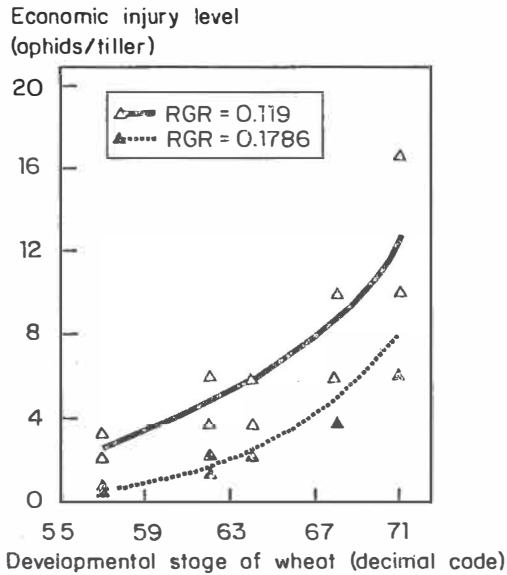

Fig. 1 Economic injury level of cereal aphids on wheat as a function of developmental stage. EILs are also influenced by assumed value of relative growth rate of aphid population. Dots represent ranges in which EILs exist. Results are based on average conditions for the Netherlands (Onstad & Rabbinge, 1985).

development of many diseases is promoted, since the latent period is longer and the infectious period shorter with low nitrogen. Another effect concerns the consequences of nitrogen status on the growth and yield reduction per unit of pest. This may vary considerably for different pests, diseases or weeds. With an increase in yield the competitive ability of a crop increases, so that the influence of growth reduction is less important. Weed control is then of less importance especially in the linear phase of crop growth. Pests and diseases are usually more important at higher yield levels. A good crop condition, needed for higher yields, and favourable micro-meteorological conditions in a dense crop may promote development of many diseases and affect the yield loss - pest density relation. The increase of winter wheat yields in Western Europe in the 1970s is for a large part due to better pest and disease control in crops with a high yield potential (Rabbinge, 1986). The increased importance of pests and diseases at higher yield levels is exemplified for cereal aphids. In wheat field experiments (Rabbinge et al., 1983) at a yield of  $5000 \text{ kg ha}^{-1}$  and a maximum density of 15 aphids at late watery ripe growth stage, these organisms caused a yield loss in kernels of  $250 \text{ kg ha}^{-1}$ , whereas a similar aphid load at a yield level of  $8000 \text{ kg}$  caused a yield reduction of  $900 \text{ kg ha}^{-1}$ . This is discussed further by Rabbinge (1987).

Apparently, cereal aphids cause progressive damage at increasing yield levels. Other diseases (e.g. mildew) cause proportional damage per unit of disease (Rabbinge, 1986). The reasons for this difference lies with the nature and manner of growth and yield reduction. In the examples above, with pests and diseases on winter wheat, such a dynamic explanatory analysis has led to better insight into the causes of damage and its

consequences for yield reduction under various conditions. The shift in importance of the dependence on crop growing conditions of various diseases is determined by crop physiological processes. When abundant nutrient conditions and other favourable circumstances prevail, CO<sub>2</sub> assimilation is very high; assimilate consumption by an aphid may increase growth rate as the plant sink is limited. Under poor conditions, however, source limitation may occur (Rabbinge & Koster, 1984). This and other physiological phenomena may affect growth reduction or, in very rare cases, promote growth rate.

The presence of such effects limits the use of fixed EILs; they are inappropriate, since yield expectation differs considerably in different circumstances. Determination of flexible EILs would require endless field experiments and it is for this reason that other methods are more appropriate. Methods based on simulation studies combined with field experiments seem to answer this need for further refinement of EILs in pest and disease management.

#### References

- Daamen, R.A. (1981). Surveys of diseases and pests of winter wheat in the Netherlands, 1979-1980. Meded. Fac. Landbouwwetenschappen, Rijksuniversiteit Gent, 46, 933-937.
- Daaman, R.A. (1987). Disease/pest observation methods. IOBC Bulletin (this volume).
- Onstad, D.W. & Rabbinge, R. (1985). Dynamic programming and the computation of economic injury levels for crop disease control. Agricultural Systems 18, 207-226.
- Rabbinge, R. (1986). The bridge function of crop ecology. Netherlands Journal of Agricultural Science 34, 239-253.
- Rabbinge, R. (1987). Dynamic explanatory models as a tool in the development of flexible economic injury levels. IOBC Bulletin (this volume).
- Rabbinge, R. & Koster, G. (1984). Some effects of cereal aphids on growth and yield of winter wheat. Proceedings of the Fourth Australian Applied Entomology Symposium. (Eds. P. Barley & D. Juringer) pp. 163-169.
- Rabbinge, R., Sinke, J. & Mantel, W.P. (1983). Yield loss due to cereal aphids and powdery mildew in winter wheat. Meded. Fac. Landbouwwetenschappen, Rijksuniversiteit Gent 48, 1154-1167.
- Shaw, M.W. & Royle, D.J. (1987a). A new methodology for disease loss studies used to estimate effects of Pyrenophora teres and Rhynchosporium secalis on winter barley yields. Annals of Applied Biology 110, 247-262.
- Shaw, M.W. & Royle, D.J. (1987b). Conceptual basis for estimation of disease-induced crop loss in field experiments. IOBC Bulletin (this volume)
- Smith, I.M., Chiarappa, L. & van der Graaff, N.A. (1984). World crop losses: an overview. In: Plant Diseases, Infection, Damage and Loss (Eds. R.K.S. Wood and G.J. Jellis). Blackwell Scientific Publications). pp. 213-225.

Stern, V.M. (1973). Economic thresholds. Annual Review of Entomology 18, 259-280.

Wood, R.K.S. & Jellis, G.J. (1984). Plant Diseases, Infection Damage and Loss. Blackwell Scientific Publications, Oxford, 325 pp.

Zadoks, J.C. & Schein, R.D. (1979). Epidemiology and Plant Disease Management. Oxford University Press, 427 pp.

DYNAMIC EXPLANATORY MODELS AS A TOOL IN THE DEVELOPMENT  
OF FLEXIBLE ECONOMIC INJURY LEVELS

R. Rabbinge and W.A.H. Rossing

Department of Theoretical Production Ecology, Agricultural  
University, Bornsesteeg 65, Wageningen, The Netherlands

Introduction

There are several ways by which pest or disease populations may affect physiological processes in plants. They may, for example, reduce crop stands by elimination of plants, reduce inputs such as light, carbon dioxide and water, interfere with transportation of assimilates or nutrients and remove or consume previously produced structural material. Fig. 1 is a relational diagram illustrating various ways in which these crop growth reducing factors may interfere. To study the quantitative meaning of various effects, simulation studies may help. Eventually, this approach will lead to insights into the mechanisms of growth and yield reduction and into the quantification of yield reduction under various circumstances.

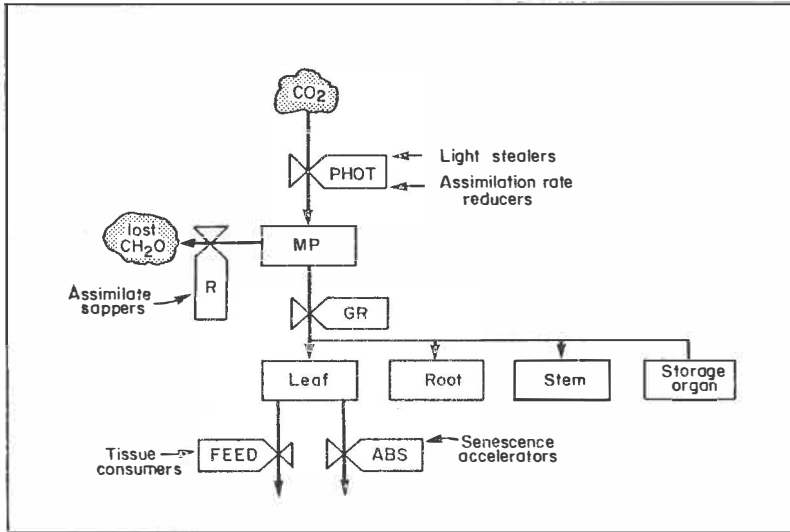

Fig. 1. Relational diagram for a Simple Universal CROP growth Simulator (MP = metabolic pool, GR = growth rate leaves, R = respiratory losses) and its interaction with various reducing factors.

Factors which define, limit and reduce crop growth

Crop growth, the accumulation of dry matter distributed between various crop organs, is determined by factors which define the physiological, phenological, optical and geometrical characteristics of the crop, providing water and nutrients are abundantly available and pests, diseases, weeds and any other crop growth-reducing factors are absent. Under these conditions, the growth of the crop is entirely governed by these characteristics and by the prevailing weather, mainly incoming radiation and temperature. Such a



situation is, however, rare since the great majority of agricultural crops suffer from water or nutrient shortage and are affected by pests, diseases and weeds.

The consequences of pests and diseases may differ considerably at different production levels. The production levels distinguished in crop growth studies have been discussed by Rabbinge (1986). He illustrated the use of combination models to evaluate the consequences of pests and diseases on crop growth and production and showed how various pests or diseases may affect different basic processes that govern growth, assuming abundant water and nutrient availability. The relational diagram in Fig. 1 illustrates this. Leaf photosynthesis may be affected by "light-stealers", or by "assimilation sap-reducers". Maintenance respiration may be increased by "assimilate and parenchyma cell-sappers". Leaf dry matter may be reduced by "tissue-consumers" or ageing may be promoted by "senescence accelerators". Some of the consequences of these perturbations are given in Table 1.

Table 1. The effects of pests and diseases on crop growth

Crop growth component	Damaging organisms	Example
(a) Rate of biomass increase	tissue consumers	Lepidopteran larvae Leaf beetles
(b) Assimilation rate:		
effects via leaf area	leaf consumers senescence promoters	leaf miners, spider mites aphids, many leaf pathogens
via incident light	light stealers	weeds, competitors, perito- trophic and saprophytic fungi
via water	turgor reducers	aphids, root- feeding coleoptera, various bacteria
via N/P/K	assimilate consumers	aphids
(c) Growth rate per organ:		
assimilate partitioning	functional balance root feeders	nematodes
assimilate conversion	assimilate consumers	aphids
(d) Leaf die-back	senescence promoters	aphids

Tissue or assimilate-consumers. An important distinction is that between tissue-consumers, which remove materials that have already been converted into plant tissue, and assimilate-consumers, which feed on unconverted assimilates. Since each kilogram of assimilate produces less than 1 kg of tissue, the tissue-consumers are more costly in terms of crop growth, although secondary damage by selective assimilate-consumers may result in higher total damage levels. Such effects are included in the rate of biomass increase as this is the net result of growth rate, rate of die-back and rate

of tissue removal by insects or other organisms. Nematodes and mites suck assimilates from host cells. The same holds for fungi which use haustoria for this purpose.

Stand reducers. Examples are damping-off fungi which reduce plant biomass and the number of plants. Consideration of reduced plant number is difficult and requires an approach in which competition for light or nutrients is considered similarly to an approach studying the effects of weeds. The distribution of captured plants in the field and the capacity of plants to compensate should then also be considered.

Assimilation rate-reducers. Many pathogens and pests affect CO<sub>2</sub> assimilation rate; they may affect the photosynthesis rate at light saturation or the light use efficiency. Mechanisms by which pathogens affect photosynthesis have been summarised by Buchanan *et al.* (1981). Viruses may reduce numbers of chloroplasts per unit leaf area or alter chloroplast ultrastructure, electron transport and partial resistance of photosynthesis. Fungi may alter chloroplast ultrastructure and certain components of the electron transport chain. Bacteria may also cause structural damage to chloroplasts. All these effects have been determined in detailed studies under well-defined conditions. However, the quantitative meaning of the effects in terms of crop growth and production is virtually unknown. Some pathogens and insects may accelerate leaf senescence by changing the nitrogen balance, or by excretion products affecting the activity of leaves.

Light stealers. Some leaf pathogens, for example pertotrophic and saprophytic fungi, have a 'light stealing' effect on crops by inhabiting dead host tissue which absorbs photosynthetically-active radiation. Leaf coverage by excretion products or light interception by leaves with necrotic lesions may interfere with photosynthesis. Coverage of leaves with mycelium may also affect light absorption.

Turgor-reducers. Nematodes that feed on roots and root pathogens that affect the water balance of the plant are examples. They also affect crop nutrient balance by disrupting phloem transport to roots, thus reducing the energy supply for active uptake of nutrients, such as K, and by disrupting passive flow of water and nutrients by the eventual decay of that tissue. Many root pathogens such as Pseudomonas spp., Fusarium spp. and Verticillium spp. can be classified as turgor reducers.

Stomatal functioning-disturbers. Some diseases, such as rusts and mildews, cause the stomatal guard cells to malfunction resulting in greater resistance to CO<sub>2</sub> uptake by well-watered plants with insufficient stomatal closure (Ayres, 1981). Whether this is a primary reaction of the plant to the host remains to be seen, as demonstrated by Rabbinge *et al.* (1985). They showed that mildew affects photosynthesis and transpiration as a result of an increase in carboxylation resistance. Stomatal resistance is only indirectly affected through a feedback mechanism from the internal CO<sub>2</sub> concentration to stomatal behaviour. Quantification is crucial for an evaluation of all these effects on crop growth and production. Such a preliminary evaluation was done in the first Bulletin of this Working Group (Rabbinge, 1983). A further analysis leading to calculated economic injury levels is given in this volume (Rabbinge, 1987).

Computation of economic injury levels using dynamic simulation models

Example 1. Powdery mildew on winter wheat. To quantify the consequences of powdery mildew *Erysiphe graminis*, a similar approach as described above could be used: mildew mycelium covering leaves could be considered as a light-stealer. However, long before a light stealing effect can be detected, the fungus affects leaf photosynthesis, as shown in Fig. 2. Mildew has an effect on dark respiration and leaf photosynthesis at light satiation;

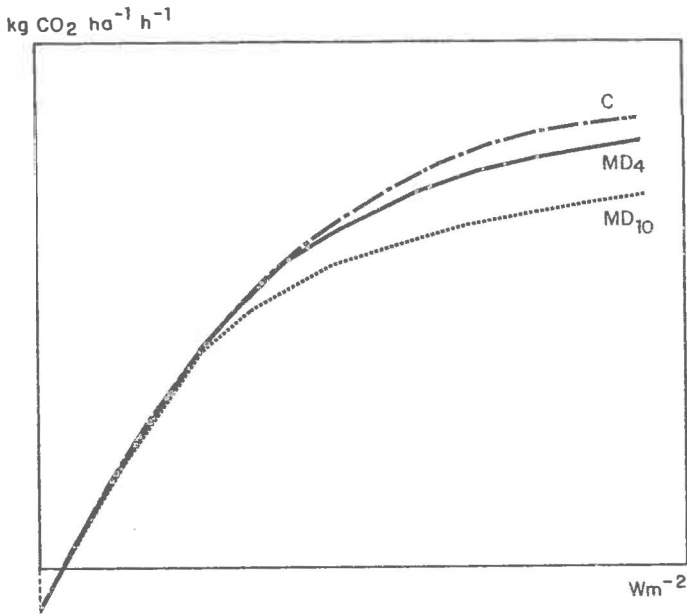

Fig. 2. Leaf photosynthesis of control (C) and powdery mildew infected winter wheat plants. MD<sub>4</sub> and MD<sub>10</sub> are leaves with a percentage coverage with mildew pustules of 4 and 10 percent respectively.

light use efficiency is hardly affected. The size of the effect is shown in Table 2 (Rabbinge et al., 1985). Even at a relatively low infection level (4% leaf area covered by pustules) both the assimilation and transpiration rates at light satiation were reduced up to 50%. Light use efficiency and dark respiration were not significantly affected. Evaluation of these effects with a multi-layered leaf photosynthesis module of a summary model for crop growth demonstrated that even at low infection levels considerable reductions in crop growth rate may occur. It was also shown that this effect is more pronounced when the sky is clear than when it is overcast (Table 3).

Table 2. Normalised values of maximum assimilation rate (AMAX in  $\text{kg CO}_2 \text{ ha}^{-1} \text{ h}^{-1}$ ), light use efficiency (EFF, in  $\text{kg CO}_2 \text{ ha}^{-1} \text{ h}^{-1} \text{ W}^{-1} \text{ m}^2$ ) and dark respiration (RD, in  $\text{kg CO}_2 \text{ ha}^{-1} \text{ h}^{-1}$ ). Mildew-infected plants were grouped in classes of percentage mildew infected leaf area (PMI).

n <sup>1</sup>	PMI class	AMAX	SD ( $\pm$ )	EEF	SD ( $\pm$ )	RD	SD ( $\pm$ )
11	control	100.0 <sup>2</sup> (45) <sup>3</sup>	3.9	100.0 (.27)	0.02	100.0 (1.33)	0.21
11	0.1 - 0.5	97.1	4.4	101.5	0.03	94.0	0.20
11	0.5 - 1.0	86.5	4.1	100.4	0.03	99.2	0.29
9	1.0 - 2.0	83.6	4.9	103.4	0.02	111.3	0.37
9	2.0 - 3.0	66.8	4.1	94.0	0.03	109.8	0.25
10	3.0 - 6.0	57.5	5.2	88.8	0.04	128.6	0.29
9	6.0 - 10.0	55.3	4.9	84.7	0.03	123.3	0.23
8	10.0	40.1	2.6	86.2	0.03	133.8	0.42

More detailed analysis of the effects of mildew on  $\text{CO}_2$ -assimilation and transpiration was done by measuring both rates at various external  $\text{CO}_2$  concentrations at the same time. Assimilation rate at light saturation as well as transpiration rate were affected to the same extent. The assimilation rate/transpiration rate ratio (A/T) was, therefore, not significantly affected by mildew infection (Table 4).

The simultaneous reduction of assimilation and transpiration rates may have been caused by two different mechanisms: one based on an increase in carboxylation resistance (I), and a second (II) based on an increase in stomatal resistance. This is illustrated in Fig. 3. Curve A represents the response of assimilation rate (P) to the internal  $\text{CO}_2$  concentration (CI).

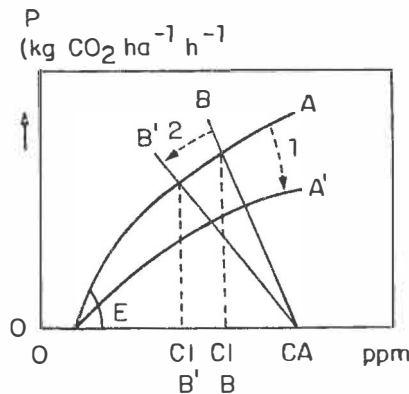

Fig. 3. Assimilation rate (P) at various internal  $\text{CO}_2$  concentrations (CI, curve A); and the  $\text{CO}_2$  supply function at various internal  $\text{CO}_2$  concentrations (line B). Effects of mildew are indicated for two hypothetical mechanisms: (1) Reduction in efficiency in  $\text{CO}_2$  absorption ( $\epsilon$ ): curve A transforms into curve A'. (2) Increase in stomatal resistance: line B transforms into line B'.

Table 3. Simulated daily gross assimilation of a wheat crop for an overcast and clear sky (DGA0 and DGAC, in kg CO<sub>2</sub> ha<sup>-1</sup> d<sup>-1</sup>, respectively), at several crop development stages (DC). The mildew (PMI) was homogeneously distributed in the crop. For comparison, AMAX values (in kg CO<sub>2</sub> ha<sup>-1</sup> h<sup>-1</sup>) are presented.

DGA0	PMI	Day 143, DC 35, LAI <sup>1</sup> = 2			Day 160, DC 50, LAI = 4			Day 173, DC 65, LAI = 4	
		DGAC	AMAX	DGA0	DGAC	AMAX	DGA0	DGAC	AMAX
0.0	100 (156.) <sup>2</sup>	100 (475.)	100 (45.)	100 (206.)	100 (644.)	100 (44.)	100 (207.)	100 (620.)	100 (39.)
0.5	99.2	96.1	91.5	99.3	96.3	91.3	99.1	95.6	90.3
1.0	98.5	92.9	85.0	98.7	93.2	84.7	98.4	91.9	82.9
2.0	97.3	87.8	75.8	97.7	88.4	75.4	97.0	86.1	72.5
4.0	95.6	81.2	65.2	96.2	82.1	64.5	95.0	78.5	60.3
8.0	93.5	74.3	55.4	94.3	75.4	54.5	92.3	70.4	49.2
16.0	91.4	68.4	48.0	92.5	69.8	47.1	89.5	63.6	40.8

<sup>1</sup> Leaf Area Index, in m<sup>2</sup> m<sup>-2</sup>

<sup>2</sup> Normalised values, control = 100. For control plants the values calculated by the model are presented in brackets.

Line B is the CO<sub>2</sub> supply function, describing the diffusion of CO<sub>2</sub> from the atmosphere (with concentration CA) to the intercellular spaces<sup>2</sup> (with concentration CI). The initial slope is made by curve A with the abscissa (E). If the first mechanism (I) is operating, then the CO<sub>2</sub> flow from the stomatal cavities to the carboxylation sites will decrease. Because of the feedback loop between internal CO<sub>2</sub> concentration, assimilation rate and stomatal conductivity, the stomata would close (Goudriaan & van Laar, 1978; Farquhar & Sharkey, 1982). Consequently the rates of gas exchange would be reduced. Investigation of this mechanism was done in a study by Rabbinge *et al.* (1985). In this study, the CO<sub>2</sub> response of assimilation rate was measured and the carboxylation resistance was calculated from the

Table 4. The ratio of assimilation (A) and transpiration rates (T) at an irradiance of 320 W m<sup>-2</sup> and ambient CO<sub>2</sub> concentration of 340 ppm for control and mildew-infected plants at DC 50.

n <sup>1</sup>	PMI class	A/T	SD
23	control	10.6	0.95
11	0.1 - 0.5	10.4	1.07
11	0.5 - 1.0	9.3	0.67
9	1.0 - 2.0	9.2	0.65
9	2.0 - 3.0	9.4	0.80
10	3.0 - 6.0	9.3	0.81
9	6.0 -10.0	9.6	0.74
8	10.0	8.9	0.53

<sup>1</sup> number of replicates

relation between internal CO<sub>2</sub> concentration (CI) and net assimilation rate at an irradiance of 320 W m<sup>-2</sup>. Mildew had no significant effect on the ratio so that stomatal resistance was not directly affected, although the presence of mechanism II may have been masked by the strong effects of mechanism I. Nevertheless, it is concluded that there is no influence of mildew on the stomatal regulation mechanism. As a result, the efficiency of water use, expressed as the assimilation/transpiration ratio, is influenced by mildew. Whatever the exact nature of the interaction may be, quantification of the effect and its consequences is necessary. This further analysis of the consequences of the effect of mildew on crop behaviour was done with the photosynthesis module of a basic crop growth model in which the effects on assimilation rate were introduced (Spitters & van Kraalingen, 1988; Rabbinge *et al.*, 1985). In the calculations a homogeneous distribution of mildew was assumed. However, a homogeneous distribution will rarely occur in practice. More often, infection will be initially located in lower leaf layers and spread to the top of the canopy. This location effect was mimicked assuming an overall value of percentage mildew infected as before, but with a concentration of the mildew in specific layers of the canopy (Table 5).

Table 5. Location effect of mildew infection on daily gross assimilation under an overcast sky (DGAO) and under a clear sky (DGAC) for crops with LAI<sup>1</sup> = 2 (DC 35) and LAI = 4 (DC 50). Starting from the top, leaf layers (LAI = 1 per layer) are numbered I to IV. The percentage mildew covered leaf area (PMI) and AMAX (in kg CO<sub>2</sub> ha<sup>-1</sup> h<sup>-1</sup>) of the diseased layers are represented by PMIL and AMAXL respectively.

Infected leaf layers	PMI = 4				PMI = 8			
	PMIL	AMAXL <sup>2</sup>	DGAO <sup>2</sup>	DGAC <sup>2</sup>	PMIL	AMAXL <sup>2</sup>	DGAO <sup>2</sup>	DGAC <sup>2</sup>
LAI = 2, DC 35:								
none	0	100	100	100	0	100	100	100
I	8	55	95	82	16	48	93	78
II	8	55	99	92	16	48	98	90
all	4	65	96	81	8	55	93	74
LAI = 4, DC 50:								
none	0	100	100	100	0	100	100	100
I	16	47	95	83	32	42	94	81
I + II	8	55	95	80	16	47	93	75
IV	16	47	100	98	32	42	100	98
IV + III	8	55	100	96	16	47	100	95
IV + III + II	5.3	60	99	91	10.7	51	98	88
all	4	65	96	82	8	55	95	75

<sup>1</sup> Leaf Area Index, in m<sup>2</sup> m<sup>-2</sup>

<sup>2</sup> Normalised values; disease-free = 100.

The effect on the gross assimilation rate was not marked when mildew was uniformly distributed over the canopy or concentrated in the upper leaf layers. When the mildew was concentrated in the lower leaf layers the reduction was smaller, and the effect of variation in the amount of mildew was substantial only when levels above 4% were reached.

The calculations above demonstrated the considerable effect of mildew on daily photosynthesis rate. The consequences for crop growth and production were evaluated using the same crop growth model for computations throughout the season. The outcomes were tested against field experiments which were done in 1983 by R.A. Daamen and I.J.M. Jorritsma (unpublished) at the experimental farm "Vreedepeel", situated on loamy sand and which is sensitive to dry conditions. The grain yields (total dry matter) attained in the control were 6500 kg compared to the potential 9000-12000 kg. Water limitation will cause a low growth rate during a part of the growing season. In the simulation, the yields were higher than 6500 kg but when a water balance was introduced which considered water shortage during the growing season, simulated and measured values corresponded better. The mildew, expressed as an integrated value of percentage mildew covered leaf area, was now introduced in the model and experimental and simulated relative yields at various mildew infection levels of the crop corresponded rather well (Fig. 4). The calculations are preliminary and a more detailed analysis by Daamen and Jorritsma is in preparation.

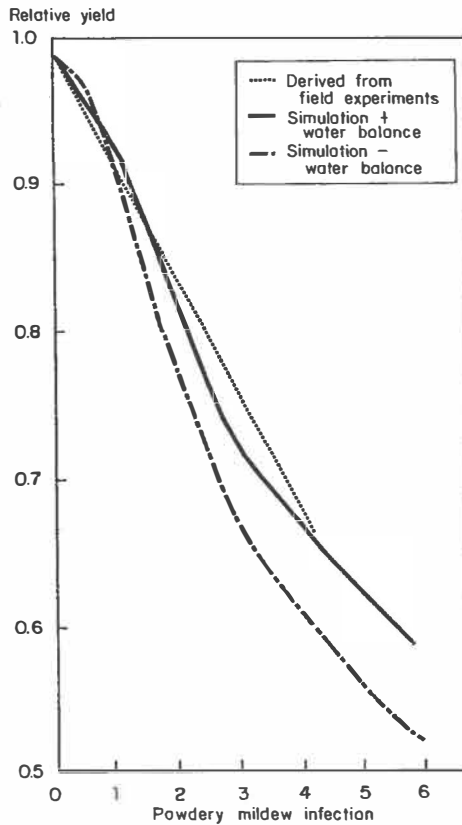

Fig. 4. Simulated and measured relative yields at various levels of mildew infection. Simulations are done with a combination model of crop growth and mildew infection, experiments are done at loamy sandy soil, (R.A. Daamen et al., unpublished)

The preliminary combination model of the growing crop and the disease has been used to evaluate the consequences of an integrated percentage of mildew severity of 3% during the growing season in crops growing at various production levels, which are dictated by water and nutrient limitations. These results (Table 6) (Schans, 1984) show that yield reduction is proportional to yield, which indicates that economic injury levels should be inversely proportional to yield.



Table 6. Simulated yield loss due to a mildew load on the plants of 3% leaf coverage during the growing season starting at DC 30, at various expected yields in kg grain ha<sup>-1</sup> (Schans, 1984).

---

Yield expected	Yield loss
6000	4800
8000	2400
10000	3000

---

Example 2. Cereal aphids on winter wheat. During recent decades aphids have become an important cause of yield loss in cereals, probably as a result of changes in crop husbandry (Rabbinge et al., 1983). In the Netherlands, the English grain aphid Sitobion avenae (F.), is usually the most abundant species on cereals.

Experiments have revealed the complex effects of S. avenae on yield loss. To quantify the effects of various dynamic processes on the growth of winter wheat, the various effects of cereal aphids (Table 7) were determined in detailed laboratory studies and introduced in a comprehensive simulation model of winter wheat of which a preliminary version is described by van Roermund et al., 1986. This was based on a detailed model of growth and development of spring wheat (van Keulen & Seligman, 1987).

Table 7 Damage components of cereal aphids on winter wheat

- 
1. Direct
    - Assimilate consumption
      - carbohydrates
      - proteins (amino acid)
  2. Indirect
    - Saliva injection
      - Honeydew production
      - reduction photosynthesis (AMAX and EFF.)
      - promoting senescence
- 

The model has been extended by incorporating a model describing the influence of S. avenae on various plant physiological parameters. Actual grain yield depends on environmental conditions, such as radiation and temperature, and on the availability of carbohydrates and nitrogen. The carbohydrate source is built up by net photosynthesis. The nitrogen source consists of translocatable nitrogen in the plant which is supplemented by nitrogen uptake from the soil. Carbohydrates and nitrogen are taken up by the grain and the competing aphids, which together form the sink. Both are characterised by their potential uptake rates.

Primary aphid damage is caused by withdrawal of phloem sap, which contains carbohydrates and nitrogen. This results in a reduction of the carbohydrate and nitrogen supply available for the grains. Secondary aphid damage is caused by the aphid excretion product, honeydew, on leaves. Honeydew reduces the maximum gross assimilation rate at light saturation (AMAX) and the light use efficiency (EFFE), resulting in a decrease of gross photosynthesis (Rabbinge et al., 1981). Recent detailed observations on the background of such effects on photosynthesis parameters have revealed some of the mechanisms (Rossing, in preparation). These effects were quantified in detailed laboratory studies, and

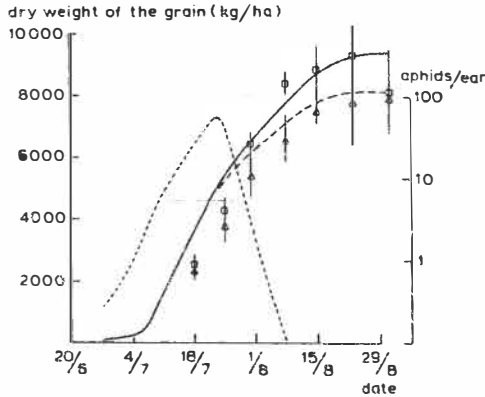

Fig. 5 Simulated (—) and measured ( $\square$ ) dry weight of the grain in the absence of aphids, simulated (---) and measured ( $\Delta$ ) dry weight of the grain in the presence of aphids and the aphid population (.....), as a function of time

introduced into the simulation model. The simulations start at anthesis (DC 60, Zadoks et al., 1974). The model is initialised with the dry weights and nitrogen fractions of the plant organs at anthesis. Measured daily minimum and maximum temperature, daily total radiation and aphid densities are used as forcing functions. A field experiment with winter wheat (*Triticum aestivum* (L.) cv. Arminda) was carried out at the experimental farm 'De Eest' in Nagele, Noord-Oost Polder in 1984 to test the model. The experiment consisted of four treatments in six replicates; control of aphids by a selected aphicide (250 g pirimicarb in 600 l water per hectare) starting at development stages DC 71 (at the onset of the aphid infestation), DC 75 and DC 77, and an untreated control. Aphid numbers were recorded at weekly intervals, the method and sample size depending on the density (Ward et al., 1985). Growth analysis of the crop was carried out weekly on 50 haphazardly chosen culms per replicate.

In the field, an aphid damage (at harvest) of  $994 \pm 322 \text{ ha}^{-1}$  was found. Aphid damage of  $1241 \text{ kg ha}^{-1}$  is simulated at a yield in the absence of aphids of  $9377 \text{ kg ha}^{-1}$  (Fig. 5).

Fig. 6 shows the different damage components simulated by the model, and their relative importance in total aphid damage at a yield in the absence of aphids of  $8562 \text{ kg ha}^{-1}$ . Although the aphid infestation started

at the end of June (with a population peak at 25 July, see Fig. 5), the simulated damage did not start until the second half of July. This is due to the reduction of the reserves in the stem at that time, i.e. when the grain growth changes from sink-limited to source-limited.

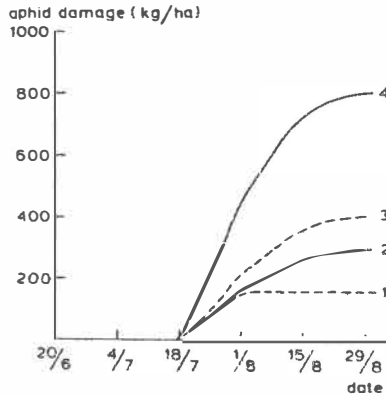

Fig. 6 Simulated damage components ( $\text{kg ha}^{-1}$  at an aphid intensity of 490 aphid-day and a yield in the absence of aphids of  $8562 \text{ kg ha}^{-1}$ ) as a function of time.

- 1 - carbohydrate withdrawal
- 2 - carbohydrate and nitrogen withdrawal
- 3 - carbohydrate and nitrogen withdrawal + AMAX reduction
- 4 - carbohydrate and nitrogen withdrawal + AMAX and EFFE reduction

Primary damage caused by removal of phloem sap forms 37% of the total damage. Carbohydrate and nitrogen withdrawal are of equal importance, although the time at which damage occurs is different; nitrogen withdrawal has a delayed effect on yield reduction.

Secondary damage, caused by AMAX and EFFE reduction resulting from honeydew deposits, is 63% of the total damage. The combination of withdrawal of phloem sap and AMAX reduction causes 51% of the total damage. The remainder is caused by EFFE reduction. Thus the reduction of EFFE caused by honeydew is the most important single component of the total aphid damage, according to this model. This is because EFFE is more sensitive to honeydew than AMAX, as has been shown in laboratory experiments (Rabbinge *et al.*, 1981) and because the simulated growth is more sensitive to EFFE than to AMAX. These results have been partially confirmed by ecophysiological field and laboratory studies of Rossing (in prep.).

The simulated damage per aphid-day is highest during anthesis of wheat, ( $5.1 \text{ kg ha}^{-1}$  per aphid day between DC 60 and DC 69 at a yield in the absence of aphids of  $8562 \text{ kg ha}^{-1}$ ), and decreases during the grain-filling period ( $0.8 \text{ kg ha}^{-1}$  per aphid-day between DC 75 and DC 77); From the field data of the four treatments, a weighted mean of  $2.5 \text{ kg ha}^{-1}$  per aphid-day has been calculated over the whole period in which aphids are present (between DC 71 and DC 79).

According to the simulation model, aphid damage increases more than linearly with the yield level in the absence of aphids up to a level of 8000 kg ha<sup>-1</sup> (Fig. 6). Various yield levels are simulated by changing the initial values of the nitrogen level in the soil, the dry weight of the plant organs, their nitrogen fraction and the AMAX. At a high nitrogen level, plants take up more nitrogen, leading to a higher nitrogen and carbohydrate content in the crop, which stimulates photosynthesis. As a result, aphids take up more carbohydrates and nitrogen, and thus cause greater primary damage. Because of a longer period in which the leaf surface is productive, more green leaf area is covered by honeydew and secondary damage is higher. With increasing yield level, the relative effect of primary damage decreases and secondary effects due to honeydew excretion are more important. Beyond a yield level in the absence of aphids of 8000 kg ha<sup>-1</sup>, aphid damage no longer increases more than linearly with yield level, and saturation occurs. This is because the crop parameters affected by aphids (e.g. nitrogen fraction, leaf area index, AMAX, EFFE) are now relatively less important in limiting grain growth. These high yields are also determined by other crop, soil and meteorological parameters before anthesis, which are not affected by aphids.

Thus, the economic injury levels in cereal aphids are changing relatively as well as absolutely with increasing yield levels. This has major consequences for supervised control as the tolerable aphid density may vary from >14 tiller<sup>-1</sup> at yields of 5000 kg grains ha<sup>-1</sup> and <3 tiller<sup>-1</sup> at yield levels of 9000 kg ha<sup>-1</sup>.

### Conclusion

The examples of combination models of crop growth and a pest and a disease have shown how they may help to gain insight into the nature and level of yield reduction, and can be used to derive economic injury levels for various crop growth conditions. These flexible economic injury levels have considerable consequences for the practical application of integrated pest and disease control. Simple clues are becoming impossible and this will lead to the use of decision-supported management tools as described in the last section of this Bulletin.

### References

- Ayres, P.G. (1981). Effects of Disease on the Physiology of the Growing Plant. Cambridge University Press, Cambridge.
- Buchanan, B.S., Hutcheson, S.W., Magyacoay, A.C. & Montalbini, P. (1981). Photosynthesis in healthy and diseased plants. In: Effects of Disease on the Physiology of the Growing Plant (Ed. P.G. Ayres). Cambridge University Press, Cambridge, pp. 13-28.
- Farquhar, G.O. & Sharkey, T.O. (1982). Stomatal conductance and photosynthesis. Annual Review of Plant Physiology 32, 317-345.
- Goudriaan, J. and van Laar, H.H. (1978). Calculation of daily totals of the grass CO<sub>2</sub>-assimilation of leaf canopies. Netherlands Journal of Agricultural Science 14, 373-383.

- Keulen, H. van & Seligman, N.G. (1987). Simulation of water use, nitrogen nutrition and growth of a spring wheat crop. Simulation Monograph, Pudoc, Wageningen, The Netherlands (in press).
- Rabbinge, R. (1983). How to use combination models in crop protection. IOBC Bulletin 1983/VI/2, pp. 31-46.
- Rabbinge, R. (1986). The bridge function of crop ecology. Netherlands Journal of Agricultural Science 3, 239-251.
- Rabbinge, R. (1987). Crop loss assessment and economic injury levels. IOBC Bulletin (this volume).
- Rabbinge, R., Jorritsma, J.T.M. & Schans, J. (1985). Damage components of powdery mildew in winter wheat. Netherlands Journal of Plant Pathology 91, 235-247.
- Rabbinge, R., Sinke, C. & Mantel, W.P. (1983). Yield loss due to cereal aphids and powdery mildew in winter wheat. Mededelingen Faculteit Landbouwwetenschappen Rijksuniversiteit Gent, België, 48/4.
- Rabbinge, R., Drees, E.M., van der Graaf, M., Verberne, F.C.M. & Wesselo, A. (1981). Damage effects of cereal aphids in wheat. Netherlands Journal of Plant Pathology 87, 217-232.
- Schans, J. (1984). Schade door meeldauw in winterarwe. Intern. rapport. Vakgroep Theoretische Teeltkunde, Landbouwniversiteit, Wageningen.
- Spitters, C.J.T., van Kraalingen & van Keulen, H. (1988). A simple and universal crop growth simulator: SUCRO587. In R. Rabbinge et al. (Ed.). Simulation and Systems Management in Crop Protection. Simulation Monograph Series, Pudoc, Wageningen (in press).
- van Roermund, H.J.W., Groot, J.J.R., Rossing, W.A.H. & Rabbinge, R. (1986). Simulation of aphid damage in winter wheat. Netherlands Journal of Agricultural Science 34, 489-493.
- Ward, S.A., Rabbinge, R. & Mantel, W.P. (1985). The use of incidence counts for estimation of aphid population. I. Minimum sample size required for accuracy. Netherlands Journal of Plant Pathology 91, 93-99.
- Zadoks, J.C., Chang, T.T. & Konzack, C.F. (1974). A decimal code for the growth stages of cereals. Weed Research 14, 415-421.

CONCEPTUAL BASIS FOR ESTIMATION OF DISEASE-INDUCED CROP LOSS IN  
FIELD EXPERIMENTS

M.W. Shaw and D.J. Royle

Department of Agricultural Sciences, University of Bristol  
AFRC Institute of Arable Crops Research, Long Ashton Research Station  
Long Ashton, Bristol, BS18 9AF, UK

For decision making in disease management schemes it is necessary to predict yields associated with different disease patterns. For example, if one can predict courses of disease with and without a fungicide application, the yield associated with each action must be estimated before a rational decision can be made. It is suggested that a useful way of thinking about the problem is to try to estimate a function relating to disease present at every instant during the growth of the crop to the final yield, through a rate of yield loss function. The integral of this function then provides an estimate of final yield (Fig. 1).

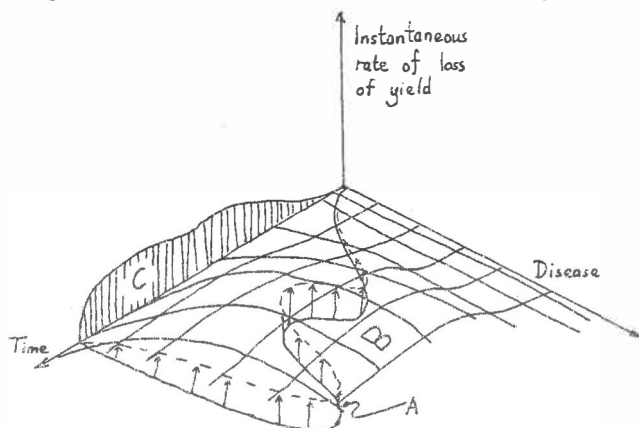

Fig. 1 The loss rate function. Curve A represents the course of disease in the disease-time plane, between sowing and harvest. Surface B is the loss rate function. At each moment,  $t$ , a projection upwards from the curve A specifies the loss rate at that moment. The total loss is the integral of the loss rate between sowing and harvest: that is, the area C.

The problem is now to estimate this function from data consisting of yields and estimated disease progress curves in a set of field plots. That is, we must estimate a set of  $\beta_i$ , the parameters of a loss rate function (or, equivalently, a yield gain rate function), from data of the form

$$y_j = \int_{\text{sowing}}^{\text{harvest}} (D_j(t), t, \beta_1 \dots \beta_m) dt + \text{error}_j$$

Often, methods of quantifying intensity are adopted by tradition. That entomologists more often use (relative) density while phytopathologists more often use severities is not only a matter of tradition. Diseases are often assessed in terms of severity because there is no common disease entity as with insect individuals. Generally speaking, dispersion, feeding and reproduction in insects are concentrated in one entity, the individual insect, while each life cycle stage in fungi is more specialised. Moreover, an adult insect is rather constant of size, while the size of a lesion with fruiting bodies may vary greatly. Rather than for reasons of tradition, an assessment method should fit the purposes of the estimates. In the context of this discussion, it is my opinion that the assessments must be quantitative, reliable and independent of the observers (researchers, advisors and farmers). The counting of (relative) density or incidence is quantitative and requires no training, provided the pest or disease can be recognised. The disadvantage of these methods is that they take time. The reliability of estimates is determined by two types of errors. First, random errors will occur due to sampling variation (precision of variation). Second, systematic errors may occur due to over- or under-estimation by observers or to the sampling procedure (accuracy of estimation).

### Sampling variation

If the sampling variation is known, a sampling procedure can be developed and the precision of the estimates described.

In the case of incidence and prevalence, the statistical distribution which underlies the estimate is the binomial distribution, so the sample variance of an incidence count can be calculated according to:  $s^2 = p(1-p)/n$ ; where  $p$  is proportion,  $n$  is sample size. The advantage of these estimates is that their sampling variation depends only on sample size and disease intensity, but not on the disease or pest species.

In the case of severity, logits, probits or arcsin transformations will stabilize variances. Then standard statistics can be used to estimate the sample variance. The sample variance of these estimates depends on the pathogen species and disease intensity and may also depend on other factors (e.g. observers, varieties). In the case of (relative) density, the distribution which underlies the estimate will often be the negative binomial distribution (Waggoner & Rich, 1981). The sample variance can then be calculated by:  $s^2 = m + km^2$ ; where  $m$  is the mean population density,  $k > 0$ .

The parameter  $k$  of the negative binomial may depend on population density (or other factors), in which case this approach is difficult to use. The sample variance can also be described by a power function (Taylor, 1961):  $s^2 = am^{*b}$ ; where  $m$  is mean population density, parameter  $a$  depends mainly on the size of the sampling unit and  $b$  depends mainly on the species (aggregation).

If the sampling variation is known, sampling strategies can be developed for specific purposes. In addition the detection level of a sampling method can be determined. The sample variance of mildew pustule counts per leaf in winter wheat was described using Taylor's power function (Fig. 1) (Daamen, unpublished). The detection level (97.5% chance of presence of the disease in the sample) of mildew pustule counts, for a sample size of 15 leaves, was estimated to be a population intensity

of 0.5 pustules per leaf. For examples of aphid sampling, see Ward et al. (1985a, b).

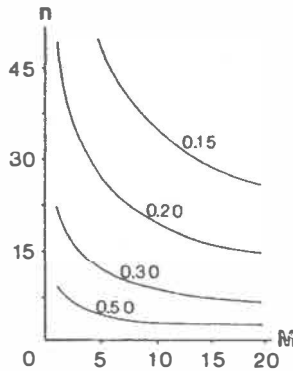

Fig. 1. Sample size (n, leaves) in relation to precision of estimated mean pustule number (M) of powdery mildew per leaf. The values plotted are the coefficients of variation of the mean

#### Bias

To describe the accuracy of an estimate is a more difficult task. A clear description of the sampling method is necessary and a critical inspection of the criteria for the sampling units may help. Bias can be introduced when transformations are used; the professional expertise of a statistician is often necessary.

The traditionally used keys for assessment of plant diseases are useful for qualitative studies (e.g. ranking of varieties or chemicals). In my opinion, however, this severity estimation prevents progress in the quantitative modelling of yield loss or population dynamics.

#### Incidence-severity (density) relations

From an applied point of view, disease incidence counts can be performed by unskilled observers and their sample variance is independent of the target species. The incidence-severity relations can relate research and farmers' information. The incidence-severity relations are summarised below; where possible, the statistical distribution which underlies the relation is mentioned (see Seem, 1984):

Poisson The relation proposed by James & Shih (1971):

$I = 100(1-r**S)$ ,  $0 < r < 1$ ; I, s are % incidence and severity; this can be derived from the Poisson distribution  $(1-I) = e**-aS$ , where I, S are proportional incidence and severity, and a is the maximal number of colonies on a leaf.

Binomial The binomial distribution yields (Daamen, unpublished, Fig. 2):  $(1-I) = (1-S)**a$ ; where I, S are proportional incidence and severity, and a is the maximal number of colonies on a leaf.



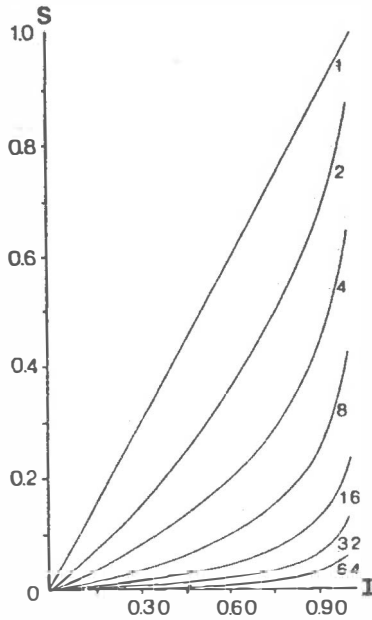

Fig. 2. Incidence (I) severity (S) relations generated by the binomial distribution, in relation to the maximal number of colonies on a leaf

Negative binomial This distribution is often used to analyse incidence: density relations (Waggoner & Rich, 1982). Here:  $(1-I) = (m/k+1)^{-k}$ ; where I is proportional incidence, m is mean population density,  $k > 0$ .

The Nachman model (Nachman, 1981) was derived without defining the statistical distribution:  $(1-I) = e^{-(tm^u)}$ ; where I is proportional incidence, m is mean population density, t and u are parameters.

Besides the above, other descriptive relations have been used, for example a probit model (Rabbinge & Mantel, 1981) for aphids and an angular model (Jeger, 1981) for apple scab.

More research is needed to clarify the nature of incidence: severity relations, for example, which family of distributions can generate the Nachman relation? For applications, the merits of these relations must be evaluated (e.g. see Ward et al., 1985a, b).

### Discussion

This paper considers only direct estimates of disease. Indirect estimation methods (e.g. remote sensing) are largely still in the research stage. Particular problems here include discrepancies between what is recorded by the sensor and what occurs in the field, a problem of diagnosis. Also, the sensitivity in remote sensing devices means that destroyed crops can be confused with pest/disease infestation levels on

living crops. Attacks of 0-5% severity are of most interest in warning systems. In epidemiology, counting methods are preferable to study these low attacks. In yield-loss studies more severe attacks are also of interest and counting methods are then time-consuming.

An interesting question is whether diseases should always be assessed in green (living) leaves or perhaps sometimes on dead leaves. This can be a problem with necrotrophic diseases of cereals. Assessment purely on dead leaves can cause overestimation of disease intensity (accumulation), whereas assessment confined to green leaves may be inappropriate if host plant varieties differ in their reaction (speed of senescence) to infection. When assessments are based on green leaves (as with biotrophic diseases) a variety interaction in yield-loss studies can be tested.

#### References

- James, W.C. & Shih, C.S. (1973). Relationship between incidence and severity of powdery mildew and leaf rust in winter wheat. Phytopathology **63**, 183-187.
- Jeger, M.J. (1982). Disease measurement in a study of apple scab epidemics. Annals of Applied Biology **99**, 43-51.
- Nachman, G. (1981). A mathematical model of the functional relationship between density and spatial distribution of a population. Journal of Animal Ecology **50**, 453-460.
- Rabbinge, R. & Mantel, W.P. (1981). Monitoring for cereal aphids in winter wheat. Netherlands Journal of Plant Pathology **87**, 25-29.
- Seem, R.C. (1984). Disease and severity relationships. Annual Review of Phytopathology **22**, 133-150.
- Southwood, T.R.E. (1978). Ecological methods. London: Chapman & Hall. 524 pp.
- Taylor, L.R. (1961). Aggregation, variance and the mean. Nature, Lond. **189**, 732-735.
- Waggoner, P.E. & Rich, S. (1981). Lesion distribution, multiple infection, and the logistic increase of plant disease. Proceedings of the National Academy of Sciences USA **78**, 3292-3295.
- Ward, S.A., Rabbinge, R. & Mantel, W.P. (1985a). The use of incidence counts for estimation of aphid populations. 1. Minimum sample size for required accuracy. Netherlands Journal of Plant Pathology **91**, 93-99.
- Ward, S.A., Rabbinge, R. & Mantel, W.P. (1985b). The use of incidence counts for estimation of aphid populations. 2. Confidence intervals for fixed sample sizes. Netherlands Journal of Plant Pathology **91**, 100-104.

## IMPLEMENTATION OF INTEGRATED CROP PROTECTION SYSTEMS

R. Rabbinge

Department of Theoretical Production Ecology, Agricultural University,  
Bornsesteeg 65, Wageningen, The Netherlands

### Introduction

The ultimate aim of research in crop protection is the introduction and application of its results into practice. To reach that goal close ties with end-users, farmers and extension need to be maintained in on-going research. The means of communication have changed during the last decade as new methods have become available. Summary models and decision rules formulated into software packages have been developed and are now being used. These methods of implementation have been considered in the last five workshop meetings of this IOBC Working Group and have resulted in some general ideas on the role of the various participants in this process of development and improvement of integrated crop protection. In this scenario integrated crop protection is viewed as part of farm management that leads to sustainable, stable and rational production of agricultural products with little use of energy or biocides per unit of product. These ideas have been substantiated in a list of steps in implementation that have been generally accepted in the Working Group. These concern activities on the levels of management of pathosystems and cropping systems. Farming systems and agroecosystems, the next higher integration levels, are not usually considered by the Working Group, although the ultimate aims of integrated crop production should be fulfilled by activities on these levels.

### Steps in developing and implementing integrated crop protection systems

Monitoring and Sampling. The basis of each supervised or integrated pest or disease control system consists of observations on the number or density of the pest or disease organisms. In some cases this can be done with indirect techniques which consider presence or absence but not numbers. However, it is often impossible to relate the actual numbers per field to counts of individuals in a suction trap or by another indirect technique. Therefore, observations in the field are needed to determine crop development and the infection level of disease or infestation level of pests. Such observations should be simple for laymen, reliable for use in initialising models, solid, i.e. take into account the specific biological requirements, and not be time-consuming. In EIPRE, for example, all observations are standardized in order to determine infection or infestation levels. These are then translated into severities or densities using statistically sound calibration techniques (Daamen, 1986; Rabbinge et al., 1981; Ward et al., 1985). In EIPRE all diseases and pests are observed in the same way, by inspecting particular leaf layers for presence or absence, and it is indicated when each disease or pest should be observed. Farmers or scouts should not spend too much time monitoring: in EIPRE no more than 1 hour ha<sup>-1</sup> year<sup>-1</sup> is recommended as a longer time would encourage too much detail and result in sampling bias. Moreover, 1 hour ha<sup>-1</sup> year<sup>-1</sup> means about 12% of all the labour required to farm one ha of wheat from sowing until harvest in present capital-intensive wheat production in Western Europe. In the U.S.A. and Australia, the labour requirement per ha of wheat is even less than 6

hours  $\text{ha}^{-1} \text{ year}^{-1}$ , therefore monitoring time should be less than 1 hour to prevent disproportionalities in time use. This is quite possible, as yield reducing factors are normally less important in situations where water and nutrient shortage limit the attainable yield, which is normally the case at yield levels between 2000 and 5000 kg of wheat  $\text{ha}^{-1}$ .

In other crops, e.g. apple, more monitoring time seems justified because of larger labour requirements for production. Research and extension should develop monitoring methods which are tailored to the specific needs of the crop and fulfil all the above criteria.

Forecasting of pest and disease severities. To decide whether control measures, biological or chemical, should be applied it is necessary to have forecasts of expected pest or disease severities and estimates of the corresponding yield reductions under the prevailing growing conditions. Such forecasts can be made with summary type models based on detailed insight of epidemiology and population dynamics or with regression type models. In the latter case extrapolation to new situations is dangerous as the system may then behave differently. Extrapolation with comprehensive explanatory models is not such a problem since the basic processes which govern the systems behaviour do not change.

Crop loss assessment. Forecasts of pest and disease severities are used to determine the expected yield loss which may depend on crop conditions, yield expectation, timing of the pathogen in the growing season and environmental conditions, as demonstrated by Rabbinge (1987) for powdery mildew and cereal aphids in winter wheat. Recommendations for control measures should be based on cost/benefit analysis. Costs of control measures should not exceed the predicted yield loss. Advice should be field-specific and take into account the history and prospects of the crop, including presence or absence of growth and yield-limiting and reducing factors. Such decision-making requires much field-specific information and information processing. Computers, even nowadays microcomputers, may be used to implement this process. This is needed even more when, for example, risk is introduced. Some farmers are risk-seeking, the majority risk-averse. However, there may not always be a logical justification for this (Zadoks, 1987). There is a clear need to make explicit the scale of risk and also the costs needed for various control measures. To do this simulation models incorporating such effects may help to quantify the consequences of various tactics. These simulation models help to make an explicit choice for risk-seeking or risk-averse behaviour; they replace "gut feelings" by "calculated risks".

Farmers' attitudes towards pest or disease control are not implicit in recommendations, and decision-making requires explicit choices. This is very important as it may change the tendency to incorporate farmers attitudes in integrated pest and disease control systems.

Implementation. Most supervised or integrated pest and disease management systems which are computerised are nowadays centralised. However, there is an increasing tendency towards decentralisation. This is made possible by the recent rapid development of appropriate hardware. In most cases appropriate software packages are not available. Moreover, the advantages of stand-alone, do-it-yourself systems may be offset by the disadvantages of delays in updating and upgrading decentralised systems.

Sudden resistance of a pest towards a pesticide will require immediate modifications in the recommendations in centralised systems; but with decentralised systems modifications can wait until the end of the season, when all updating and upgrading of software packages is done. Therefore, decentralisation may have some disadvantages which may be overcome by a combination of centralised software development with decentralised operation. Computer networking and new communication systems may be helpful. For the development of software, research, extension and private industry need to interact closely. Vital for quality in the software packages sold to end-users is for the incorporated information to be objective and scientifically sound. The independent role of research institutes and government-supported extension services is therefore justified.

Role of research and extension. A supervised control system is not an end in itself. It is a part of the cropping system which is constantly changing in response to environmental changes. It is therefore necessary to adapt and improve integrated control systems frequently. Choice of crop varieties changes, resistance against disease may be broken, resistance against certain pesticides may develop and agronomic measures, such as sowing or crop rotation, may be changed. This is why a continuous updating of control systems is needed. Research and extension are responsible for this updating as part of other agronomic activities. Another role concerns upgrading of the system. When a supervised or integrated control system is compiled, much of the information and many recommendations are based on empirical data and the experience (so called "green fingers") of the scientist or extension officer. With increase of knowledge and insight this type of experience can be replaced by quantitative facts which are transferable and understandable, i.e. "green fingers" are steadily replaced by "green brains". However, the complexity of farm management will always need the experience and care of the farmer. Computer simulation and knowledge may support his decision-making and help to improve it, but they cannot replace it.

Results of implementation. The use of models as integrative tools has been stressed in other contributions to this Bulletin. It is this role of models which has made them so powerful for research. Models as vehicles for decision-making are nowadays promoted more and more. However, it is not yet possible to demonstrate clear successes. In some crops, e.g. cotton, apple, wheat and grape, computer-sustained supervised control systems which comprise models at various levels of sophistication have been introduced. Their immediate use may be limited but will grow when the objective of crop protection is broadened to crop management or even wider, farm management systems. The impact of first generation systems like EPIPPE is already impressive (Zadoks, 1987). It is not the number of users but their general attitude towards crop protection in wheat that is of importance. Their environmental consciousness, their general attitude towards chemical crop protection, especially reluctance in spraying, their cost consciousness and acceptance of aesthetic "damage" in the Netherlands can be credited to EPIPPE. Effects of these attitudes are shown in a comparison between various systems of pest and disease control in the Netherlands and England (Table 1). This comparison may seem unfair to the extension service of England and Wales, but nevertheless shows how effective chemical companies have organised their extension messages in Britain. The difference between systems of wheat growing in the Netherlands and the U.K., due to farm size and other

Table 1. Crop protection measures in winter wheat. Data from England are based on the Boxworth experiment and extension data; data from the Netherlands are based on EIPRE and extension data.

	England			Netherlands		
	Intensive	Integrated	Reduced	Intensive	Integrated	Reduced
<b>Pesticides</b>						
Slugs	+	0	0	-	-	-
Aphids (virus)	+	+	0	-	-	-
Frit fly	+	0	0	-	-	-
Grain aphid	+	+	+	+	0	0
Rose grain aphid	+	+	+	+	-	-
<b>Fungicides</b>						
Seed treatment	+	+	+	+	+	+
GS 31	+	0	0	+	0	-
GS 39	+	+	+	-	-	-
GS 59	+	0	0	+	0	0
GS 71	+	0	0	-	-	-
<b>Herbicides</b>						
Pre-sowing	+	-	0	-	-	-
Pre-emergence	+	-	0	-	-	-
Post-emergence	+	+	+	-	-	-
Spring	+	+	+	+	+	+
Pre-harvest	+	-	+	+	-	-
<b>Growth regulators</b>						
GS 31	+	+	+	+	0	0
GS 41	+	-	-	+	-	-

+ spraying at predetermined development stages or times, or when symptoms are visible

0 optional; only when predetermined pest/pathogen density is reached

- no spraying against these organisms

Intensive: Intensive crop protection

Integrated: Reduced use of control measures, using monitoring and forecasting methods and fixed action thresholds

Reduced - Reduced crop protection, using monitoring and forecasting methods, flexible well-defined action thresholds, and calculated risks

GS = Crop Growth Stage (decimal scale of Zadoks et al. (1974).

factors, also explains some of the differences, but without doubt the use of pesticides per kg of wheat is far less in the Netherlands than in England or Schleswig Holstein (W. Germany). The input of labour needed for monitoring is clearly higher in the Netherlands, but this offsets the reduced cost of chemical compounds. Apparently chemical energy can be partly replaced by brains energy!

More research and proper extension activities may help in this way to optimise, rather than maximise, agricultural production. High stable yields require high inputs but a very high labour efficiency. The efficiency of other inputs is also promoted when enough knowledge is brought to the farmer's field. This will continue to require co-operative effort among research, extension, private industries and farmers.

#### References

Daamen, R.A. (1986). Measures of disease intensity in powdery mildew (Erysiphe graminis) of winter wheat. 2. Relationship and errors of estimation of pustule number, incidence and severity. Netherlands Journal of Plant Pathology **92**, 207-223.

Rabbinge, R. (1987). Dynamic explanatory models as a tool in the development of flexible economic injury levels. IOBC Bulletin (this volume).

Rabbinge, R., Drees, E.M., van der Graaf, M., Verberne, F.C.M. & Wessels, A. (1981). Damage effects of cereal aphids in wheat. Netherlands Journal of Plant Pathology **87**, 217-232.

Ward, S.A., Rabbinge, R. & Mantel, W.P. (1985). The use of incidence counts for estimation of aphid populations. I. Minimum sample size required for accuracy. Netherlands Journal of Plant Pathology **91**, 93-99.

Zadoks, J.C. (1987). EPIPPE: research, development and application of an integrated pest and disease management system for wheat. IOBC Bulletin (this volume).

Zadoks, J.C., Chang, T.T. & Konzak, C.F. (1974). A decimal code for the growth stages of cereals. Weed Research **14**, 415-421.

DISEASE INTELLIGENCE AND DECISION-BASED SYSTEMS IN FRANCE

B. Cure

Institut Technique des Cereales et des Fourrages (I.T.C.F.)  
Boigneville F. 91 720 MAISSE, France

Introduction

At the present time different organisations, like I.T.C.F. and Service de la Protection des Vegetaux (S.P.V.) are working on monitoring of cereal diseases, forecasting their development and strategies and programmes to help decision-making for the farmer. Using a computer programme to aid decision-making, these different studies allow the farmers to integrate data from their own observations. Data are used from survey networks of cereal diseases and from forecasting models of disease development.

Two I.T.C.F. programmes to aid decision-making are now in operation. One has been used in the northern part of France for a few years, and the other has recently been set up in the South West. Studies by S.P.V. and I.T.C.F. on forecasting models of disease development are in progress. Since 1976 S.P.V. has been managing a survey and monitoring network throughout the country for diseases of the main crops, particularly cereals. The I.T.C.F. investigations are being carried out in different regions, particularly in the South West. The first results on brown rust (Puccinia recondita) are beginning to be used in practice to forecast explosive epidemic attacks.

Decision-based systems in France

Recently, I.T.C.F. has set up two systems to aid decision-making adapted to crop conditions in two areas of France. The first, "FONGIMETOD", has been in operation for a few years. It is distributed and used in Northern France and exists in two versions: a computerised television program, and a chart with slides.

The second, 'OBSERVER POUR GAGNER', is distributed and used as a leaflet in the South West.

Principle of "FONGIMETOD". The aim is to determine for each field whether it is necessary to treat and if so, when, and with what product. The questions which the farmers have to answer concern, first, agronomic factors concerning the field crop. These take into account the previous crop, soil cultivation, date of drilling, crop variety and density and use of a growth regulator. Some climatic data of the previous winter and spring are also given for a limited area around a meteorological station belonging to the international network. All these factors give an assessment of the basic risk at two growth stages, GS 31-32 and GS 59 and at three levels: low (score < 10 points), medium (10-13) and high (> 13).

From the second group of questions to be answered the specific risk is determined. This is created from observations of one or more diseases in a particular field. The farmer will be advised to apply a treatment if a threshold is reached at 5 stages of growth. These are, for example: (i) 20% of tillers affected by eyespot at the beginning of stem extension (GS 31); (ii) More than 50% of the area of one of the three upper leaves



affected by mildew just before earing (GS 57); and (iii) for Septoria spp. the quantity of rain 1 month before heading is taken into account as well as the appearance of lesions on one of the three upper leaves.

Six diseases can be observed by the farmer. To determine the specific risk, the farmer needs to make records of eyespot and Fusarium, mildew, yellow rust, brown rust, Septoria, and Fusarium on ear, as they occur. The five growth stages are jointing, 1 to 2 nodes, booting, heading and 10-15 days after heading.

The need to treat and the choice of fungicide depends on the combination of replies given to the basic risk and to the specific risk. Different fungicide products are classified. Not all the diseases on wheat are included in the risk assessments. Eyespot (P) is the only stem base disease. Sharp eyespot, take-all, and Fusarium spp. are not used because of the absence or low efficacy of fungicides against these diseases. We discriminate between commercial products with different effects on resistant (P\*) and sensitive (P) strains of eyespot. Fungicides must be efficient on mildew (O) on leaves or ears and on rusts (R), both yellow and brown. On Septoria spp. (S) fungicides must be efficient on both S. nodorum as well as S. tritici. On Fusarium spp. on the ear fungicides are noted with a special sign when they are clear for this disease.

For each of these disease groups there are three levels of fungicide efficacy (Table 1): not advised (no letter), irregular or low efficacy (letter with brackets) and high efficacy (letter without brackets).

Table 1. FONGIMETOD

		FUNGICIDE CLASSIFICATION							
		FOOT ROT, LEAVES and EAR DISEASES		LEAVES and EAR DISEASES					
		P	O	S	R		O	S	R
P = Eyespot O = mildew S = septoria sp R = rusts  O = good efficacy (O) = medium efficacy		P	O	S	R		O	S	R
		P	(O)	S			(O)	S	
		P*	(O)	S			(O)	(S)	
		P	(O)	(S)			O		R
		P	O		R		(O)		(R)
		P							S
	P*						(O)		

P\* Eyespot caused by MBC resistant strains is controlled by thistype of fungicide

Examples of decisions from basic and specific risks levels are shown in Table 2.

Table 2 FONGIMETOD Rules to make decision

① LOW BASIC RISK

BASIC RISK	SPECIFIC RISK	TYPE OF FUNGICIDE			
LOW	O	NO TREATMENT AT THAT STAGE			
LOW	i.e. yellow rust		O		R

② MEDIUM BASIC RISK

BASIC RISK	SPECIFIC RISK	TYPE OF FUNGICIDE			
MEDIUM	O	P	(O)	(S)	
MEDIUM	i.e. septoria	P	(O)	S	

③ HIGH BASIC RISK AT 1-2 NODES STAGE

BASIC RISK	SPECIFIC RISK	TYPE OF FUNGICIDE			
HIGH	O	P	O	S	R
HIGH	i.e. eyespot	P*	(O)	S	
		+			
			O		R

④ HIGH BASIC RISK AT HEADING

BASIC RISK	SPECIFIC RISK	TYPE OF FUNGICIDE			
HIGH			O	S	R
HIGH	i.e. fusarium on ear.	P	O	S	R

Principles of OBSERVER POUR GAGNER. This strategy has been developed from a statistical analysis of more than 1000 comparisons of treated and untreated plots, in 400 trials, 1977-1984. Fungicide treatments are characterised according to the expected yield response.

(i) Where the expected yield response is > 0.8 t/ha, sprays are required and regularly profitable. This occurs in intensified crops sown before 15 November, > 250 plants/m<sup>2</sup>, > 140 units N after a leguminous crop or > 180 N after maize or sorghum, where there are regular yields (> 6.5 t/ha),

areas where the risk of disease development is high and with varieties with a low disease resistance.

(ii) Where expected yield response is about 0.4 t/ha and at least 1 fungicide spray is profitable. This occurs in situations where there are regular yields of 4.5-6 t/ha, in areas where the risk of disease development is low, and with highly resistant varieties and shallow soils.

(iii) Where the yield response is irregular and a fungicide spray is often not profitable, as with damaged crops and those with yields < 4.0 t/ha.

The risk of losses due to diseases has been estimated from quantified agronomic factors, taking into account the previous crop, the second previous crop, soil depth, nitrogen fertilisation, date of sowing, variety and region.

Fig. 1 shows the relation between the yield response from two sprays and the agronomic risk rate. The horizontal line represents the approximate cost of two sprays (0.5 t/ha). It crosses curve Y1 at the risk rate 12. Two treatments are generally profitable for risk rates > 12 but not for those < 12.

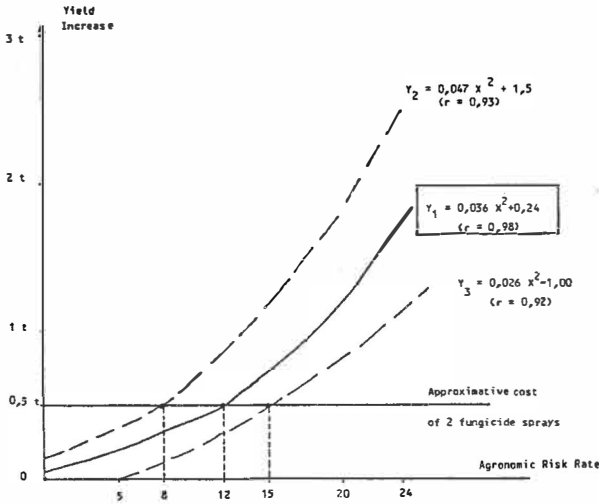

Fig. 1. Relations between yield increase and agronomic risk rate

The line for 0.5 t/ha also crosses curves Y2 and Y3, at the rates of +8 and +15 respectively. That is to say it is highly probable (statistical risk of 1%) that above +15, two fungicide sprays are economic and that below +8, two fungicide sprays are not justified.

This study has shown that, in south west France, the risk factors which influence the development of diseases are the same as in northern France. Initially it was thought that in the south west climatic conditions exerted greater influence than agronomic risk which was not so.

Nevertheless, climatic data must be taken into account in forecasting development of diseases, particularly brown rust, the main disease in this area, and also in determining accurately spray dates.

Brown rust prediction model in south west France

A weakness in programmes to aid decision-making lies in defining thresholds which are imprecise because of not taking into consideration climatic conditions and inoculum pressure.

Studies on *P. recondita* in south west France (Lauragais) allows two types of epidemics to be characterised and correlated with two types of treatment programme (Fig. 2).

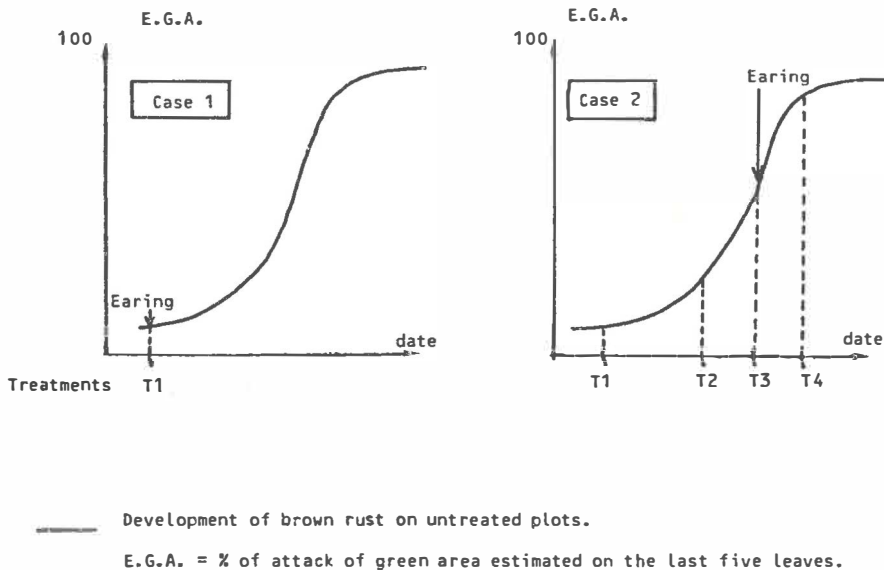
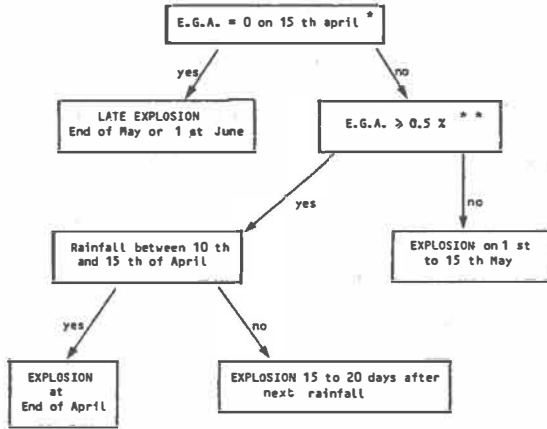

Fig. 2. Spraying programs according to the development of brown rust in wheat

If attacks start after heading (Case 1), one spray just beforehand is necessary. In the south this spray will coincide with the usual treatment at heading. If, on the other hand, attacks are early, before heading (Case 2) and if only one spray is applied, the most profitable time is at T2, just before the attack. However, in most cases two treatments will be necessary, the first at T1 2-3 weeks before an attack, the second at T3 when the effects of the first treatment have worn off. In this case T3 is appropriate with the usual treatment at heading against *Septoria*.

Analysis of epidemics between 1979 and 1985 (Fig. 3) shows that earliness of attacks depends on the quantity of inoculum at the beginning of crop growth (depends on sowing date), and the dates of rainfall in March and April.

E.G.A. = % of attack of green area estimated on the last five leaves



\* EGA = 0 means EGA < 0.01 % corresponding to 1 ou 2 pustuls on F5 or F4

\*\* EGA > 0.5 % corresponds to 25 pustuls on F5, 21 pustuls on F4, or 12 pustuls on F3.

Fig. 3. Chronology of epidemics of brown rust in the Lauragais area

The disease intelligence network of S.P.V.

In 1976 the Ministry of Agriculture's Plant Protection Service set up a survey network for cereal diseases and pests. In most cereal regions the network facilitates the detection of epidemics and pathogen/pest populations so that the farmers can be warned of the risks. Farmers are encouraged to compare their plots with the regional situation provided by the intelligence disease network. The network also enables technicians and farmers to be trained and informed of recent techniques for the control of diseases and pests, and it helps them to rationalise treatments in such a way that they make the best use of pesticides.

All data are processed by computer and are derived from three sources: a network of 497 meteorological stations in 1984, the network "CERESMAR" which consists of 2000 cereal plots (75% wheat) observed weekly over the entire country (these observations are collected by 1570 observers (56% of farmers), and a network of trials (180 in 1984).

Data which were collected by post over the last few years are gradually being collected automatically. In 1985, about 30% of local observers were connected by the Minitel system.

CEREAL DISEASE CONTROL IN ENGLAND AND WALES: ADVICE OF THE  
AGRICULTURAL DEVELOPMENT AND ADVISORY SERVICE

R.J. Cook

Agricultural Development and Advisory Service, Brooklands Avenue,  
Cambridge, CB2 2DR, UK

Introduction

The Agricultural Development and Advisory Service (ADAS) survey of winter wheat diseases in 1985 indicated that over 90% of crops in England and Wales received one or more sprays of fungicide during the 1985 season. Results of the survey also indicated that disease levels were as high as in any year since the surveys began in 1970. During that 15 year period fungicide treatment has become an essential part of the agronomy of cereals.

Sources of advice

Farmers receive advice from several sources, the most important of which is probably their chemical supplier. However, information from ADAS is widely used by all parts of the industry, as a source of impartial information. In this respect much of the advice used in decision making comes from ADAS.

Since the introduction of cereal fungicides the Service has several series of experiments designed to collect data on control of specific diseases as well as on the general effects of fungicides on cereal crops. Analysis of the results of these trials has enabled us to present a set of simple disease control guidelines.

The Managed Disease Control (MDC) system has been published as a part of three leaflets as well as in booklet form (Anon., 1985) for each of the three main cereals. The system integrates the need for routine treatment, where the risk of disease is high, with a risk assessment treatment for use in those situations where there is an immediate risk of disease causing yield loss. These leaflets have been available for free distribution to farmers as well as their advisors, whether in commercial or private employ, and trade representatives.

In addition, during the growing season, a series of regional nationally co-ordinated reports summarising disease development is produced as frequently as needed. Most regions produce these reports at weekly intervals during the period April to July.

The reports also include details of disease infection risk for the main cereal diseases as recorded since the previous report. These infection criteria are based on empirically derived associations of disease and weather as recorded at synoptic stations operated by the Meteorological Office. Daily weather reports are compiled centrally and distributed to plant pathologists through the Ministry of Agriculture, Fisheries and Food (MAFF) computer network.

### Developments

During the next few years we envisage substantial changes will occur in the way on which we disseminate advice. MDC has been developed to provide a simple and easy to follow set of guidelines for use by farmers. In its present form it makes no attempt to provide detailed guidance, tailor-made to specific fields or based on quantified disease assessments. Neither does it attempt to provide a cost-benefit analysis for use in those situations where the decision may be particularly risky.

Microcomputer-based versions have been prepared, but most just emulate the printed leaflets. One program uses the data on which the wheat system is based to provide a cost-benefit. In addition the flow diagrams have been mounted on the public viewdata system Prestel.

We are likely to make increased use of information technology (IT) in the future as a means of spreading the expertise of our specialists more widely and also as a means of raising revenue. ADAS is now starting to develop commodity related IT packages and work on a package for wheat is now in hand. It is anticipated that computer technology will improve the efficiency of our present procedures and allow us to complete field specific advice incorporating a cost-benefit analysis.

It is likely that these systems will incorporate conventional risk assessment methods until such time as we can develop precise yield loss models for our diseases and also more precise causal relationships to determine infection periods.

### References

Anon. (1985). Managed Disease Control. Leaflets. MAFF Publications, Alnwick.

Use of Fungicides and Insecticides on Cereals. Booklet 2257. MAFF Publications, Alnwick.

EPIPPE: RESEARCH, DEVELOPMENT AND APPLICATION OF AN INTEGRATED  
PEST AND DISEASE MANAGEMENT SYSTEM FOR WHEAT

J.C. Zadoks

Laboratory of Phytopathology, Agricultural University, Binnenhaven 9,  
6709 PD Wageningen, The Netherlands---

Introduction

EPIPPE is a disease and pest warning system for wheat, developed in the Netherlands. EPIPPE is an acronym representing EPIdemiology for PREdiction and PREvention. It is an early specimen of world-wide attempts to develop computerised systems for Integrated Pest Management (IPM), e.g. CIPM (1983), Ives et al. (1984). The word integrated has a dual meaning. EPIPPE integrates various aspects of chemical control, crop husbandry, bvarietal choice and farm economics. It also integrates control of five fungal diseases and several aphid pests.

This paper is a kind of post-mortem analysis of a project: the development of EPIPPE. For the initiation of the project, in 1976, there was both motive and occasion. The occasion was the rising interest of Dutch wheat farmers in intensive wheat growing, following the example of northern Germany where a 10 t ha<sup>-1</sup> yield could be obtained by applying some 10 chemical treatments. The motive was more complex. On the one hand, there was the strong desire to do 'something useful' with existing knowledge of plant disease epidemiology and computer science. On the other, there was a serious concern about the environmental effects of frequent applications of systemic chemicals, still new in 1976, over large acreages. The motive, activated by the occasion, induced the author to subject a project proposal to the Netherlands Grain Centre, which accepted it for funding. The project began in April, 1977. The execution was entrusted to Mr F.H. Rijsdijk.

Scientific aspects of EPIPPE

We know the sequence 'Research, Development, Application' from industry. The project proposed referred to this by stating that EPIPPE was not a research project but a development project which should lead to widespread application of existing knowledge.

Phytopathological knowledge. The proposal stated that sufficient phytopathological knowledge was available to develop a disease warning system, specifically for yellow rust (*Puccinia striiformis*), well known in the Netherlands, e.g. Hogg et al. (1969), Zadoks (1961). Yellow rust was the first disease to be 'developed'. In retrospect, this statement is no more than a hypothesis which is incorrect. With a view to practical application of existing knowledge, the literature abounded in redundant information but revealed few useful facts.

Economic knowledge. Economic knowledge was found to be inadequate. The costs of treatment were known but little information on the benefits of treatments was available. Some information was even misleading (Rijsdijk, 1979). The damage thresholds then in use had no scientific foundation. A rough-and-ready approach was chosen for EPIPPE. Detailed



examination of results from experiments in chemical control led to workable figures which were gradually improved. The objective was not to predict benefits to the nearest guilder, but to see whether a treatment would or would not produce profit at a given production level.

Computer knowledge. Computer knowledge seemed adequate. Dynamic simulation models of plant pests (Carter et al., 1982; Rabbinge et al., 1979) and diseases (Kampmeijer & Zadoks, 1977; Rijsdijk & Rappoldt, 1979; Waggoner et al., 1972, Zadoks, 1979) were known. The programming language CSMP (Anon., 1975) and FORTRAN had no secrets. Soon it was found that dynamic simulation models were too slow for EPIPPE, if they were to be applied a hundred times a day, even on the University's then modern DEC 10 computer. The beautifully dressed simulation models had to be subjected to a striptease. The bare results consisted only of exponential equations.

Modelling was one thing, but data handling another. Again the premise of satisfactory knowledge, as stated in the project proposal, was wrong. Great effort and much time had to be invested in data handling. The 1978 version of EPIPPE used a primitive home-made data base constructed in FORTRAN. Later versions of EPIPPE used a formal Data Base Management System (Ratliff, 1982), compatible with FORTRAN.

System design. The separation into phytopathological knowledge, economic knowledge, and computer knowledge is essentially wrong. 'Development' implies integration of all relevant knowledge into one operational system (Rabbinge & Rijsdijk, 1984; Rijsdijk, 1980; Zadoks, 1984a). We had no notion of system development methodology (Hice et al., 1978).

The system design is simple. Inputs are transformed into outputs. The inputs are the field-specific data provided by the participants. The outputs are the field-specific recommendations made to the participants. The transformation is accomplished by means of a set of rules representing our phytopathological and economic knowledge (Zadoks, 1984a).

As EPIPPE was intended to serve hundreds of individual fields, the problem of handling large masses of data outweighed any scientific problem, at least in the beginning. On peak days, some 300 postcards with field data arrived with the 9.00 am mail. The same number of recommendations were computer-printed and despatched by the 5.00 pm mail that same day.

Counter-scientific approach. Scientifically, the crux is in the rules which contain our phytopathological and economical knowledge in algorithmic form. The rules are equations with variables and constants, usually called parameters. Parameters, in turn, may be variables to be calculated by specific algorithms. The literature furnished but few good rules and it let us down completely in parameter estimation. There was neither intention nor opportunity to engage in research; the task was development. The approach chosen was pragmatic, opportunistic even and, in a way, counter-scientific.

Several short-cuts were taken, one in the area of rules. Consider the frequency distribution of fields against the intensity of the disease in those fields. The zone of low disease intensities, where no treatment was

needed, was disregarded as was the zone of high disease intensities, where the need for treatment was obvious. Attention was concentrated on the intermediate zone of uncertainty, where decision support might be welcome. Another short-cut was taken in the area of parameter estimation. Scores of trial data were scrutinised for varietal resistance, fungicide effectiveness, and so on. Conclusions were laid down in a three-class notation: dangerous, not so dangerous and not dangerous. The method allowed the systems engineer two degrees of freedom: changing the class attribution and changing the parameters attached to the classes.

An information vacuum existed on the epidemiological effects of fungicides (Zadoks, 1977). Two types of data had to be plugged in for every fungus and active ingredient combination: the fraction of the fungus killed and the duration of protection provided by the fungicide. To complicate matters, trial data indicated that these parameters interacted with cultivars. Here, common sense was the only guide (Rijsdijk, 1983; Zadoks, 1984a).

Weather data were not utilised. One reason was that no good quantitative rules were available linking weather data to future disease intensities. Another was that field data as provided by the participants were already, so to say, integrals of the effect of past weather on disease. As weather forecasts were too poor to be useful, the counter-intuitive decision was taken to skip weather as an input.

Forward flight. The 1978 participants were benevolent but critical. They did not want a one-disease-only warning system, and they said so. Farmers had to face several diseases at the time and they were beginning to use broad-spectrum fungicides. Obviously, broad-spectrum problems, controlled by broad-spectrum fungicides required a broad-spectrum EIPRE. There was then a dilemma. Either diseases could be handled in depth, as originally planned, adding them one by one and then losing the interest of the participants in the process, or a broad but superficial EIPRE could be assembled, retaining participants' interest. The latter course was chosen, relying on year-to-year improvement.

Advances in later years were technical rather than fundamental, with one exception. In 1979, Dr R. Rabbinge contributed his knowledge on cereal aphids (Carter et al., 1982; Rabbinge et al., 1979; Rabbinge et al, 1981). Annually, EIPRE was updated after detailed discussions with representatives of the Extension Service and of research institutes. The recommendations were improved. They became more contentious in that they showed the losses and gains expected from different harmful agents and various control options. They ended with a recommendation: don't treat, wait and see, or treat.

#### Human aspects of EIPRE

Preparation of the elementary system design was in 1977. In 1978, EIPRE was tested in practice. The co-operation of many people was needed. Whatever the intricacies of the system are, it is made for human beings. Without good user relations even the best system will fail mercilessly. The actors belonged to two groups: the target group, called 'participants', and the domestic forces, consisting of the EIPRE team and its Supervising Committee.

Domestic forces. The EPIPARE team, with warm support from the sponsor, was enthusiastic and self-confident, which was irritating and unjustifiable to some spectators but proved quite justified in retrospect. The team worked assiduously and accomplished the impossible within a limited time and with a limited budget. The Supervising Committee was composed of all those interested, representatives of farmers, Extension Service, sponsor, colleagues and team members. With this support, the team had to approach our target group, the farmers, and to recruit participants.

### Target group.

#### Recruitment of participants

The term participant requires explanation. The team was convinced that doing something for the farmers implied doing it with the farmers who had to be involved from the start. The term participant seemed to characterise their involvement. Participants were made 'partners in crime', with the obvious implication of avoiding claims for legal liability. Participants were expected to criticise the team freely, and they did.

The public was sensitized by an information campaign in the rural press. Obviously, the time was ripe for headlines such as 'COMPUTER FIGHTS YELLOW RUST', and other such nonsense. The actual recruitment was done annually by the Extension Service. In 1978, over 300 farmers, nicely scattered over the Netherlands, subscribed.

The team's problem was not the recruitment of but the interaction with the participants. Interaction should be sufficiently frequent to get the necessary information to and fro, but it should not let the work drown in the innumerable cups of coffee prescribed by rural protocol!

#### Interaction with participants

Interaction with the participants took the various forms of regional sessions, field instructions, printed instructions, mail, telephone and field sorties by team members. Regional sessions of participants, local extension agents, and the EPIPARE team took place in early spring for registration and instruction, and in the autumn for evaluation. Annual reports were distributed among participants and other interested parties.

The essential information was exchanged by means of postcards: up to the team with field observations, down to the participants with recommendations. At the time, mail services were adequate. Turn-over time from participant to team and back to participant again was 3 working days, at most. Turn-over time, weekend delays and holiday delays were incorporated in the computer programs and were thus dealt with in the recommendations. The telephone answering service, which began in 1979, was much appreciated by the participants. They otherwise missed the personal touch.

In 1978 and 1979 all registered fields were visited by a team member at least once, sometimes up to six times. In this way, the team did much trouble-shooting. The amount of trouble was amazingly low. Warnings were

wrong in less than one half per cent of the cases. Corrections could usually be applied at the next interaction round, without financial loss to the farmer.

#### Field monitoring

EPIPRES comparative advantage was due to its field-specificity (Zadoks et al., 1984). Every field is registered separately, with its own peculiarities and must be monitored for pests and diseases. EPIPRES requires the participant to do the monitoring, for two reasons. First, the participant should be educated to diagnose his own situation. Second, if computers are given rubbish, they produce rubbish; it is the participant's responsibility to provide good input data, the team's responsibility to provide good output data.

#### Reactions of participants

Participants registered one or more fields. Although computers were not yet popular, no participant objected to recommendations "coming from the computer". The source of recommendations was of no concern to them, so long as Mr Rijdsijk, whom they trusted, handled the instrument. This is in contrast to the attitude of some researchers whose reactions were variously 'benevolent incredulity' to 'violent feelings' and had strong opposition to computer usage.

Comments received from the participants were both negative and positive. There were two frequent negative reactions: the turn-over time is too long, (a technical objection which is more a matter of feeling than of fact), and that farmers felt they did not earn money by participating (Blokker, 1983), which is not quite true (Zadoks, 1984b). On average, the earnings are positive, varying from 10-100 guilders/ha, an amount too small to give the farmer a feeling of earning extra income (Rossing et al., 1985).

Positive reactions were specific or general. A specific reaction was "Last year EPIPRES saved my crop", and as an explanation "EPIPRES compelled me to go out and look at the crop. I found a severe attack by eyespot. It was a narrow escape". Positive reactions of a more general nature centred around two points: "I was forced to go out and look at the crop myself" and "I learned so much about pest and disease control in wheat" (Blokker, 1983). Both reactions had the sense of "and I liked it".

Transfer of EPIPRES. The final step in a development project is its transfer to the user. Once more I come back to the trika, research, development and application. Research is an important task of the University. Development, according to some, is not. Certainly, routine application is beyond the terms of reference of a Dutch university. In 1980, negotiations were started with a few interested parties to transfer EPIPRES. An extra trial year, 1981, was required to test EPIPRES's performance. The request was granted by the sponsor.

The Ministry of Agriculture became interested for its own reasons, which are, supposedly:

- (a) EPIPRES provided a certain alibi for the Ministry's apparent lack of environmental concern

- (b) EIPPRE, the only computerised management system in arable crop husbandry, could serve as a bridge toward more general computerised crop management systems
- (c) EIPPRE has introduced a new principle in agricultural extension, which might come in handy in restructuring the Extension Service.

The Ministry finally decided to continue EIPPRE for at least one further experimental year, 1982, at another institution, the Research Institute for Arable Crops (PAGV) at Leystad, with a new team. The new team was instructed by the old one, and that was the end of the development phase of EIPPRE. The application phase began in 1982 and was continued (Reinink, 1984).

### Results

Looking back, what are the results of the EIPPRE development project? There are several criteria:

- (a) Were hypotheses (statements in project proposal) confirmed?
- (b) Have attitudes changes?
- (c) Were innovations realised?

#### Statements in the project proposal.

- (a) the implicit hypothesis, that an IPM system for wheat could be constructed in a relatively short time, was confirmed. EIPPRE covers more diseases and pests and is more 'integrated' than ever expected.
- (b) The explicit hypothesis, that the literature provided sufficient information, was rejected (at least for diseases). Procedures had to be adapted to a degree that I call counter-scientific.
- (c) The idea, that the target group (the 'farmers-participants') should be involved from the beginning was correct and fruitful.
- (d) The promise to transfer the system to an appropriate institution for application was kept.
- (e) The claim that EIPPRE was to be financially self-supporting could not be substantiated. At the national level the project was profitable (Zadoks, 1984b).

#### Changes in attitude.

- (f) Evaluation studies (Blokker, 1983) indicated that participants were almost unanimously appreciative of the learning effect. As a spin-off, EIPPRE farmers also looked more critically at crops other than wheat.
- (g) The author believes that EIPPRE has influenced the Extension Service, which shows less interest in risk avoidance. (Rijdsijk, 1979) and cosmetic effects and more interest in profitability of treatments than before.
- (h) Step by step, EIPPRE and standard recommendations converged (Reinink, 1985 pers. comm.), so that the comparative advantage of EIPPRE decreased.

(i) The interest in intensive wheat farming, with a treatment index of around ten, which was the stimulus to trigger the conception of EPIPPE, dwindled in the Netherlands. EPIPPE, with its emphasis on benefit-cost relations in crop protection, has probably contributed to that effect.

#### Innovations.

(j) EPIPPE was the first operational computerised IPM scheme in Europe, possibly in the world, demonstrating that such schemes are feasible.

(k) EPIPPE was one of the first IPM scheme with explicit benefit-cost calculations, moving away from the critical period approach towards the threshold approach (Zadoks, 1984c, 1985).

(l) The routine use of EPIPPE in Belgium, England (to a limited extent), northern France (served from Belgium), Sweden and Switzerland are spin-off benefits (Zadoks, 1983).

(m) EPIPPE obviously affected research in Wageningen, which became more practically oriented.

(n) Students became more interested in farmer problems.

#### Epitome

Within the crop protection sciences, the development of EPIPPE was a medium-sized project, but it had ramifications in many segments of society in the Netherlands and beyond. The idea to distinguish research, development and application and to maintain that distribution, was effective. Development clearly delineated the project from other activities, and gave the project acceptability, purpose, and impetus. However, a rigid distinction of research, development and application is artificial and unjustified. Research without development may become a sterile exercise, producing more of the same instead of new information. Application reorientates research and continuously questions development. Development without research can be innovative but risky, as EPIPPE showed convincingly. Development needs guidance from research as well as from the society which it should serve.

#### References

Anon. (1975). Continuous System Modeling Program III (CSMP III). Program Reference Manual. SH 19-7001-3. IBM Technical Publication Department, White Plains (USA). 206 pp.

Blokker, K.J. (1983). Computergesteunde voorlichting. Een decisiegericht voorlichtingskundig onderzoek naar EPIPPE en andere geautomatiseerde infortmatiesystemen. (Decision-oriented extension research). Thesis, Wageningen. 389 pp.

Carter, N., Dixon, A.F.G. & Rabbinge, R. (1982). Cereal aphid populations: biology, simulation and prediction. Simulation Monographs. Pudoc, Wageningen: 91 pp.

CIPM (1983). Consortium for integrated pest management. Success Stories. (no publisher stated, probably Texas A & M University), 198 pp.

- Hice, G.F., Turner, W.S. & Cashwell, L.F. (1978). System development methodology. Amsterdam, North Holland Publ. Co., 2nd Ed. 449 pp.
- Hogg, W.H., Hounam, C.E., Mallik, A.K. & Zadoks, J.C. (1969). Meteorological factors affecting the epidemiology of wheat rusts. World Meteorological Organisation, Technical Note No. 99, Geneva, Switzerland. 143 pp.
- Ives, P.M., Wilson, L.T., Cull, P.O. et al. (1984). Field use of SIRATAC: An Australian computer-based pest management system for cotton. Protection Ecology 6, 1-21.
- Kampmeijer, P. & Zadoks, J.C. (1977). EPIMUL, a simulator of foci and epidemics in mixtures, multilines and mosaics of resistant and susceptible plants. Simulation Monographs. Pudoc. Wageningen, 50 pp.
- Rabbinge, R., Ankersmit, G.W. & Pak, G.A. (1979). Epidemiology and simulation of population development of Sitobion avenae in winter wheat. Netherlands Journal of Plant Pathology 85, 197-220.
- Rabbinge, R., Drees, E.M., van der Graaf, M., Verberne, F.C.M. & Wesselo, A. (1981). Damage effects of cereal aphids in wheat. Netherlands Journal of Plant Pathology 87, 217-232.
- Rabbinge, R. & Rijsdijk, F.H. (1984). Epidemiological and crop physiological foundation of EIPRE. In: Cereal production (ed. E.J. Gallagher). London: Butterworths, pp. 227-235.
- Ratliff, W. (1982). dBASE II Assembly-language Relational Database Management System. User Manual. Ratliff Software Production, Ashton Tate, Culver City (Cal.). 186 pp.
- Reinink, K. (1984). Recent experiences in computerized pest and disease control in the Netherlands. Proceedings of the 1984 British Crop Protection Council Conference, Pests and Diseases, pp. 685-690.
- Rijsdijk, F.H. (1979). Verliezen in de nederlandse tarweteelt. Gewasbescherming 10, 196-199.
- Rijsdijk, F.H. (1980). Systems analysis at the cross-road of plant pathology and crop physiology. Zeitschrift Pflanzenkrankheiten Pflanzenschutz 87, 404-408.
- Rijsdijk, F.H. (1983). The EIPRE system. In: Decision making in the practice of crop protection. (ed. R.B. Austin). British Crop Protection Council Monograph No. 25, pp. 65-76.
- Rijsdijk, F.H. & Rappoldt, K. (1979). A model evaluation of spore dispersal inside and above canopies. Proceedings 1st International Conference of Aerobiology, Munich, pp. 407-410.
- Rossing, W.A.H., Schans, J. & Zadoks, J.C. (1985). Het project Eipre, projectanalyse in de gewasbescherming. Landbouwkundig Tijdschrift 97, 29-33.
- Waggoner, P.E., Horsfall, J.G. & Lukens, R.J. (1972). EPIMAY, A simulator of southern corn leaf blight. Bulletin Connecticut Agricultural Experiment Station, New Haven, No. 729, 84 pp.

Zadoks, J.C. (1961). Yellow rust on wheat, studies in epidemiology and physiologic specialization. Tijdschrift over Plantenziekten (Netherlands Journal of Plant Pathology) **67**, 69-256.

Zadoks, J.C. (1977). On the epidemiological evaluation of fungicide action. Netherlands Journal of Plant Pathology **83**, (Supplement 1), 417-426.

Zadoks, J.C. (1979). Simulation of epidemics: problems and applications. EPPO Bulletin **9**, 227-234.

Zadoks, J.C. (1981). EIPRE: a disease and pest management system for winter wheat developed in the Netherlands. EPPO Bulletin **11**, 365-369.

Zadoks, J.C. (1983). An integrated disease and pest management scheme, EIPRE, for wheat. In Better Crops for food, Ciba Foundation Symposium 97, (ed. J. Nugent & W. O'Connor), pp. 116-129. London, Pitman.

Zadoks, J.C. (1984a). EIPRE, a computer-based scheme for pest and disease control in wheat. In Cereal Production (ed. E.J. Gallagher). Butterworth, London, 354 pp.

Zadoks, J.C. (1984b). Analyzing cost-effectiveness of EIPRE. EPPO Bulletin **14**, 61-65.

Zadoks, J.C. (1984c). A quarter century of disease warning, 1958-1983. Plant Disease **68**, 352-355.

Zadoks, J.C. (1985). On the conceptual basis of crop loss assessment: The threshold theory. Annual Review of Phytopathology **23**, 455-473.

Zadoks, J.C., Rijsdijk, F.H. & Rabbinge, R. (1984). EIPRE: A systems approach to supervised control of pests and diseases of wheat in the Netherlands. In Pest and pathogen control. Strategic, tactical and policy models (ed. G.R. Conway), Wiley, Chichester pp. 344-351.



EXPERIENCE AND CURRENT STATUS OF EIPRE IN SWITZERLAND

H.R. Forrer

Swiss Federal Research Station for Agronomy, 8046 Zürich, Switzerland

The EIPRE system was introduced into Switzerland in 1981. The first participants were ten cantonal plant protection advisers for arable farming. Through this opportunity they were trained to recognise wheat diseases. In the same year we started to evaluate EIPRE, in co-operation with the plant protection service in the whole wheat growing area of Switzerland (Table 1).

Table 1 Number of EIPRE wheat fields and trials in Switzerland 1981-85, and spray applications made in response to EIPRE recommendations

Year	Number of fields	Number of trials	Mean number of treatments against		EIPRE modifications
			fungi	aphids	
1981*	24	23	0.9	0.4	-introduction of a field specific septoria factor
1982	48	40	0.5	0.3	-adaption of the aphid model (population peak at stage 73)
1983	93	66	0.8	0.0	-first year to consider eyespot disease
1984	96	69	0.7	0.1	-consideration of actual rain data in the septoria model
1985	256	90	1.3	0.04	-45 advisers and agricultural teachers connected

\* EIPRE recommendations were not always followed in 1981 since fungicides against mildew had not yet been authorised.

Each adviser was responsible for one or more wheat fields. In all or a portion of each field, EIPRE was compared with one or two other treatments in two replications. These treatments were an untreated control and/or a traditional control schedule. At growth stage 73-83 disease severity in all treatments was evaluated. Shortly before harvest, 2 x 8 samples of two 1 m lengths and row were taken per treatment.

At the Agricultural Experiment Station Zürich-Reckenholz, the samples were threshed. After drying, water content, weight and 1000 grain weight of the samples were measured.

In Switzerland high quality bread wheat with relatively good disease resistance is cultivated over more than 95% of the wheat area. The price guaranteed by the State is between 1.00 and 1.10 Swiss francs for 1 kg wheat. In 1984, EIPRE farmers obtained an average yield of 7030 kg/ha

(15% water), a gross return of 7422 sFr and a corrected gross return of 7182 sFr/ha<sup>1</sup>. In 1985 there was rainy weather from April to mid-June, necessitating 1.3 fungicide treatments in the EPIPARE programme. The mean yield of the 90 test fields was 6770 kg/ha, the gross return 7080 sFr/ha and the corrected gross return 6690 sFr/ha. The corrected gross return is the gross return minus the costs for the fungicides and insecticides, the application costs, the costs of applications and 100 sFr for secondary costs (e.g. resistance to pesticides, encouragement of other or new parasites).

A comparison of EPIPARE (1981-1985) with the other treatments showed that, on average, the yield with EPIPARE was 10% and the corrected gross return 4% higher than in the untreated control. Also, the yield on the traditionally-treated plots was 3% higher, but the corrected gross return was 0.5% lower than in EPIPARE.

A comparison of the three treatments in 1985 is shown in Fig. 1. The differences are significant between untreated and EPIPARE. There are no significant differences between EPIPARE and traditional treatment.

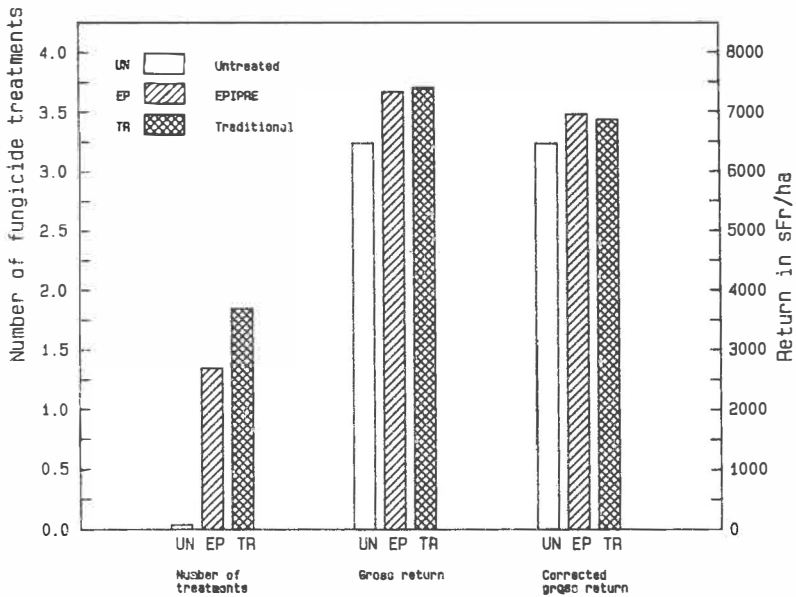

Fig. 1. Comparison of fungicide spray frequency and gross returns of EPIPARE with untreated control and a traditionally-sprayed winter wheat (Results of 26 trials in Switzerland in 1985)

<sup>1</sup> after 0.7 fungicide treatments

Farmers make no more profit by following EPIPARE, but they were able to reduce the spray frequency from between 20-100%. This is not only ecologically valuable but also helps to reduce selection pressure for fungicide resistance. EPIPARE is also useful for those farmers who choose not to follow the system, since a weekly disease bulletin is generated with EPIPARE survey data and distributed to the local advisory services.

In 1985 our research station accepted a maximum of 500 farmers to participate in the EPIPARE system. In addition, 70 farmers had the opportunity to test a Videotex version (interactive television system) that was developed in co-operation with the Swiss agricultural co-operatives. From 1987 EPIPARE will be distributed completely by this organisation.

EXPERIENCES AND RESULTS FROM THE USE OF EIPRE IN SWEDEN

Annika Djurle

Swedish University of Agricultural Sciences, Research Information  
Centre/Plant Protection, PO Box 7044, S-750-07 Uppsala, Sweden

Background

The Dutch EIPRE system (Rabbinge & Rijsdijk, 1983; Zadoks, 1981) was tested experimentally in Sweden between 1982-1985. EIPRE was introduced to Sweden for several reasons. It might serve as a means of limiting unnecessary spraying in winter wheat, thereby optimizing the farmer's profit and also reducing the risks of development of pesticide resistance. The educational effects of EIPRE could likewise be important. Many farmers eagerly seek more information and knowledge and this system could provide them with useful advice in one package, and help them decide whether or not to spray in individual fields.

Before EIPRE was introduced into Sweden only minor adjustments of the original program were made to suit Swedish conditions. The general set-up and organisation is the same as in the Netherlands (Rijsdijk, 1982). EIPRE has been tested in five regions, but mainly in the southernmost part of the country (EIPRE-region 1) and in the eastern central part (EIPRE-regions 4 and 5). In all, EIPRE has been examined in about 130 field experiments over the 4 years, and in 30-100 farmer-surveyed fields per year.

Results

Results from the experiments in region 1 show that the net yields of EIPRE (yield minus costs) in 1982-1984 were of the same order as scheduled spraying, which means an average net yield increase of 12% compared to untreated plots. With EIPRE this was achieved with the same number of treatments (1.5 per plot) but with fewer chemicals (1.8 instead of 2.7) compared to scheduled spraying (Djurle & Jonsson, 1985). In 1985 the number of treatments was the same as before, but neither EIPRE nor other treatment strategies gave a surplus.

In regions 4 and 5, neither the use of EIPRE or scheduled spraying resulted in any significant yield increase over the 4 years, though the costs of treatment were less for EIPRE (Djurle & Jonsson, 1985; Jonsson & Djurle, 1986). The pressure from pests and diseases is generally lower than in the southern regions, which could explain the differences in the success of EIPRE.

The experiences from involving farmers in the project are similar to those of the Dutch in relation to farmers' general opinions (Blokker, 1984; Swedish farmers' personal communications). Farmers' adherence to EIPRE's recommendations is, however, different and varies between regions. Whereas the majority of farmers in region 1 treat more than EIPRE recommends, the farmers in regions 4 and 5 treat according to EIPRE or less (Djurle & Jonsson, 1985).

## Discussion

In general EIPRE has worked well, but in its present state it is not sufficiently reliable to be introduced to farmers for routine usage. Some improvements are needed before that step is taken. Although EIPRE results in less use of chemicals than with scheduled spraying, some unnecessary spraying is probably still recommended by EIPRE. This is partly an effect of the actual weather conditions and the lack of meteorological parameters in the program. It is planned to introduce, for example, rainfall data into the program in future.

The plant growth model in EIPRE, which is a function of temperature, does not work satisfactorily. As the developmental stage of the crop influences the values of other parameters in the program, the growth model needs to be correct. An investigation (J.F. Angus (1985) unpublished) shows that the day-degree accumulations for wheat development in Sweden does not correspond with EIPRE's predictions of developmental stages. This seems to be a combined effect of slower growing wheat varieties in relation to temperature and the length of the photoperiod. New day-degree accumulations have now been proposed and will be tested.

No economic evaluation has yet been done to estimate the overall profit from general use of EIPRE in winter wheat in Sweden. However, it is clear that EIPRE is an interesting system well worth pursuing further and improving. If EIPRE is to be recommended for general use, it will not be before 1987. Until then the program will be carefully analysed in order to identify weak and unclear points in the aphid and disease models, strengthen them wherever possible and initiate new research areas that later can be incorporated into EIPRE.

## References

- Blokker, K. (1983). Computerized extension: what can be learned from EIPRE and other computerized information systems in agricultural extension? Paper presented at the 6th European Seminar on Extension Education, Lucca, Italy, 6 pp.
- Djurle, A. & Jonsson, U. (1985). [EIPRE - a computerized pest and disease management system for winter wheat tested in Sweden]. Sveriges Lantbruksuniversitet, Vaxskyddsrapporter Jordbruk 32, 179-189 (English summary).
- Jonsson, U. & Djurle, A. (1986). [EIPRE in Sweden - results and future plans]. Sveriges Lantbruksuniversitet, Vaxskyddsrapporter Jordbruk 39, 91. (English summary).
- Rabbinge, R. & Rijsdijk, F.H. (1983). EIPRE: a disease and pest management system for winter wheat, taking account of micro-meteorological factors. EPO Bulletin 13, 297-305.
- Rijsdijk, F.H. (1982). The EIPRE SYSTEM. In: Decision Making in the Practice of Crop Protection, (Ed. R.B. Austin) British Crop Protection Council Publications, pp. 65-76.
- Zadoks, J.C. (1981). EIPRE: A disease and pest management system for winter wheat developed in the Netherlands. EPO Bulletin 11, 365-369.

